

A. フレーム関係 / Machine body / Maschinengehäuse / Corps de la machine / Cuerpo de la máquina

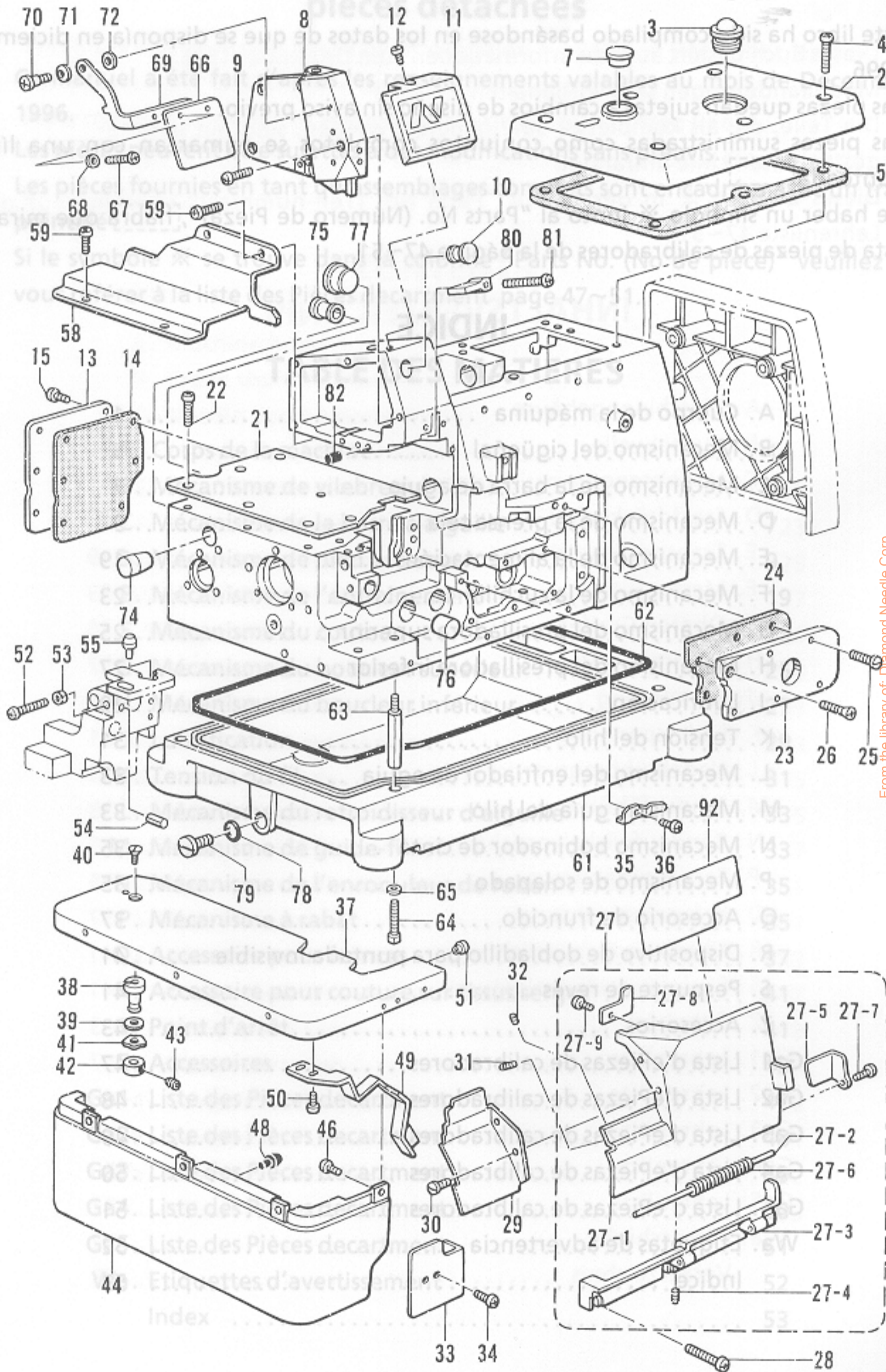

From the library of: Diamond Needle Corp

A. フレーム関係 / Machine body / Maschinengehäuse / Corps de la machine  
/ Cuerpo de la máquina

REF.NO.	CODE	Q'TY	ヒンメイ	NAME OF PARTS	RM
2	S39605001	1	ウツカバー	TOP COVER	
3	S02606000	1	ユリヨウケイマド	OIL GAUGE WINDOW	
4	062401012	6	ナベコM4X10	SCREW, PAN M4X10	
5	S39606020	1	パツキン	PACKING	
7	S23337009	1	ゴムセン18.5	RUBBER CAP, 18.5	
8	S39607001	1	ソクメンカバー	FRAME SIDE COVER	
9	062400812	5	ナベコ4X8	SCREW, PAN M4X8	
10	S20345009	1	ゴムセン14	RUBBER CAP, 14	
11	S39608021	1	メンイタカバー	FACE PLATE COVER	
12	060400612	1	バインドM4X6	SCREW, BIND M4X6	
13	S20310001	1	オクリキコウカバー-B	COVER FOR FEED MECHANISM, B	
14	S39771020	1	パツキン	PACKING	
15	060400812	6	バインドM4X8	SCREW, BIND M4X8	
21	S39610021	1	オクリダイカバー	FEED BAR COVER	
22	060400812	6	バインドM4X8	SCREW, BIND M4X8	
23	S39564021	1	ウチカバー	INSIDE COVER	
24	S39563020	1	ウチカバーパツキン	INSIDE COVER PACKING	
25	S23616101	5	シメネジ4X10	SCREW, M4X10	
26	061400812	1	サラコM4X8	SCREW, FLAT M4X8	
27	S39611001	1	マエカバーLクミ	FRONT COVER ASSY, L	
27-1	S39612001	1	マエカバーL	FRONT COVER, L	
27-2	S39613001	1	マエカバーヒンジジク	FRONT COVER HINGE SHAFT	
27-3	S20319001	1	マエカバーヒンジ	FRONT COVER HINGE	
27-4	012400432	2	アナヒラ4X4	SET SCREW, SOCKET (FT) M4X4	
27-5	S20320101	1	マエカバーストツバ	FRONT COVER STOPPER	
27-6	S20321001	1	マエカバーバネ	FRONT COVER SPRING	
27-7	060400612	1	バインドM4X6	SCREW, BIND M4X6	
27-8	S20327101	1	マエカバートメイタ	STOPPER PLATE, FRONT COVER	
27-9	060400612	1	バインドM4X6	SCREW, BIND M4X6	
28	060401412	3	バインドM4X14	SCREW, BIND M4X14	
29	S38304001	1	マエカバーS	FRONT COVER, S	
30	S23418002	2	シメネジ4X5	SCREW, M4X5	
31	012400832	1	アナヒラ4X8	SET SCREW, SOCKET (FT) M4X8	
32	012400432	1	アナヒラ4X4	SET SCREW, SOCKET (FT) M4X4	
33	S20324101	1	マエカバーLアンナイ	FRONT COVER GUIDE, L	
34	060400612	2	バインドM4X6	SCREW, BIND M4X6	
35	S20325001	1	マエカバートメイタバネ	PLATE SPRING	
36	060400612	1	バインドM4X6	SCREW, BIND M4X6	
37	S39562001	1	クロスプレート	CLOTH PLATE	
38	S39623001	1	クロスプレートササエジク	CLOTH PLATE SHAFT	
39	141183000	1	クロスプレートシート	CLOTH PLATE SHEET	
40	100032003	1	サラネジ4.37	SCREW, FLAT SM4.37	
41	100315002	1	ナミバネ	SPRING, WAVE	
42	S39624021	1	セットカラー	SET SCREW COLLAR	
43	012060632	2	アナヒラ6X6	SET SCREW, SOCKET (FT) M6X6	
44	S38301020	1	クロスプレートシタ	CLOTH PLATE, LOWER	
46	060400612	4	バインドM4X6	SCREW, BIND M4X6	
48	S20412000	2	ゴムセン3.7	RUBBER CAP, 3.7	
49	S39625051	1	クロスプレートトメイタバネ	SPRING, PLATE	
50	060400612	2	バインドM4X6	SCREW, BIND M4X6	
51	156482000	1	セン4	CAP, 4	
52	062401212	1	ナベコ4X12	SCREW, PAN M4X12	
53	021400212	1	2シユナツト4	NUT, 2 M4	
54	047602042	1	スプリングピン6X20	PIN, SPRING ROLL 6X10	
55	S20412000	1	ゴムセン3.7	RUBBER CAP, 3.7	
58	S39626021	1	クロスプレートヌノアンナイ	CLOTH GUIDE	
59	060400612	3	バインドM4X6	SCREW, BIND M4X6	
61	S20338200	1	アブラウケ	OIL PAN	
62	S20339000	1	パツキン	PACKING	

From the library of: Diamond Needle Corp

A. フレーム関係 / Machine body / Maschinengehäuse / Corps de la machine / Cuerpo de la máquina

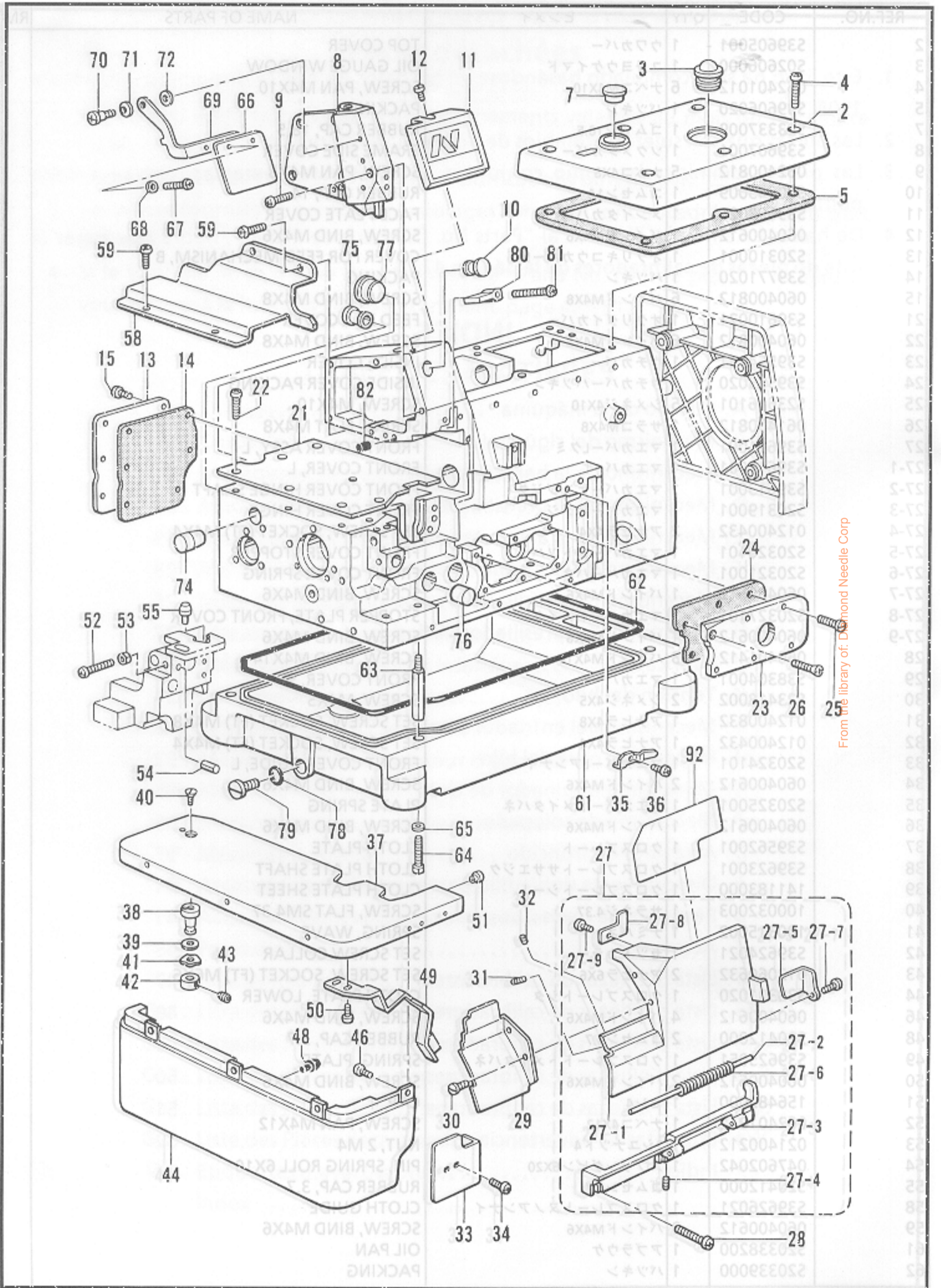

From the library of: Diamond Needle Corp

A. フレーム関係 / Machine body / Maschinengehäuse / Corps de la machine  
/ Cuerpo de la máquina

REF.NO.	CODE	Q'TY	ヒンメイ	NAME OF PARTS	RM
63	S23350001	4	ホンタイシチユウ	MACHINE BODY LEG	
64	017501212	4	ボルト5X12	BOLT, M5X12	
65	S23351001	4	ザガネ	WASHER	
66	S00075000	1	アイガード	EYE GUARD	
67	060350812	2	バインド35X8	SCREW, BIND M3.5X8	
68	025350332	2	ヒラザガネダイ3.5	WASHER, PLAIN L 3.5	
69	S20340001	1	アイガードササエイタ	EYE GUARD SUPPORT PLATE	
70	S20342001	1	ダンネジ4	SHOULDER SCREW, M4	
71	146598001	1	バネザガネ	WASHER, SPRING	
72	025050132	1	ヒラザガネシヨウ5	WASHER, PLAIN S 5	
74	140325001	1	ゴムセン10.3	RUBBER CAP, 10.3	
75	S20345009	1	ゴムセン14	RUBBER CAP, 14	
76	154841009	1	ゴムセン16.8	RUBBER CAP, 16.8	
77	S23337009	1	ゴムセン18.5	RUBBER CAP, 18.5	
78	081009070	1	OリングP9	O RING, P9	
79	S23357001	1	シメネジ10	SCREW, M10	
80	S20346000	1	ハリボウアブラウケ	NEEDLE BAR OIL RESERVOIR	
81	062401612	1	ナベコM4X16	SCREW, PAN M4X16	
82	S20878000	1	ゴムセン5.3	RUBBER CAP, 5.3	
92	S39784001	1	イトトオシセツメイラベルC	THREADING DIAGRAM LABEL, D	
24-2	S39563001	1	<シンクロナイザ用> プーリ	<FOR SYNCHRONIZER> PULLEY	
1-1	S39759001	1	“ハイリフト用” <22-25,27,28,33,34,37,38,41,42,45,46,49> クランクシャフトOHクミ	FOR "HIGH-LIFT" CRANK SHAFT, OH ASSY	
1-2	S39760001	1	“エクストラハイリフト用” <22,25,27,28,33,34,37,38,41,42,45,46,49> クランクシャフトOEクミ	FOR "EXTRA HIGH-LIFT" CRANK SHAFT, OE ASSY	

From the library of: Diamond Needle Corp

B. 駆動軸関係 / Crank shaft mechanism / Kurbelwelle / Mécanisme de vilebrequin / Mecanismo del cigüeñal

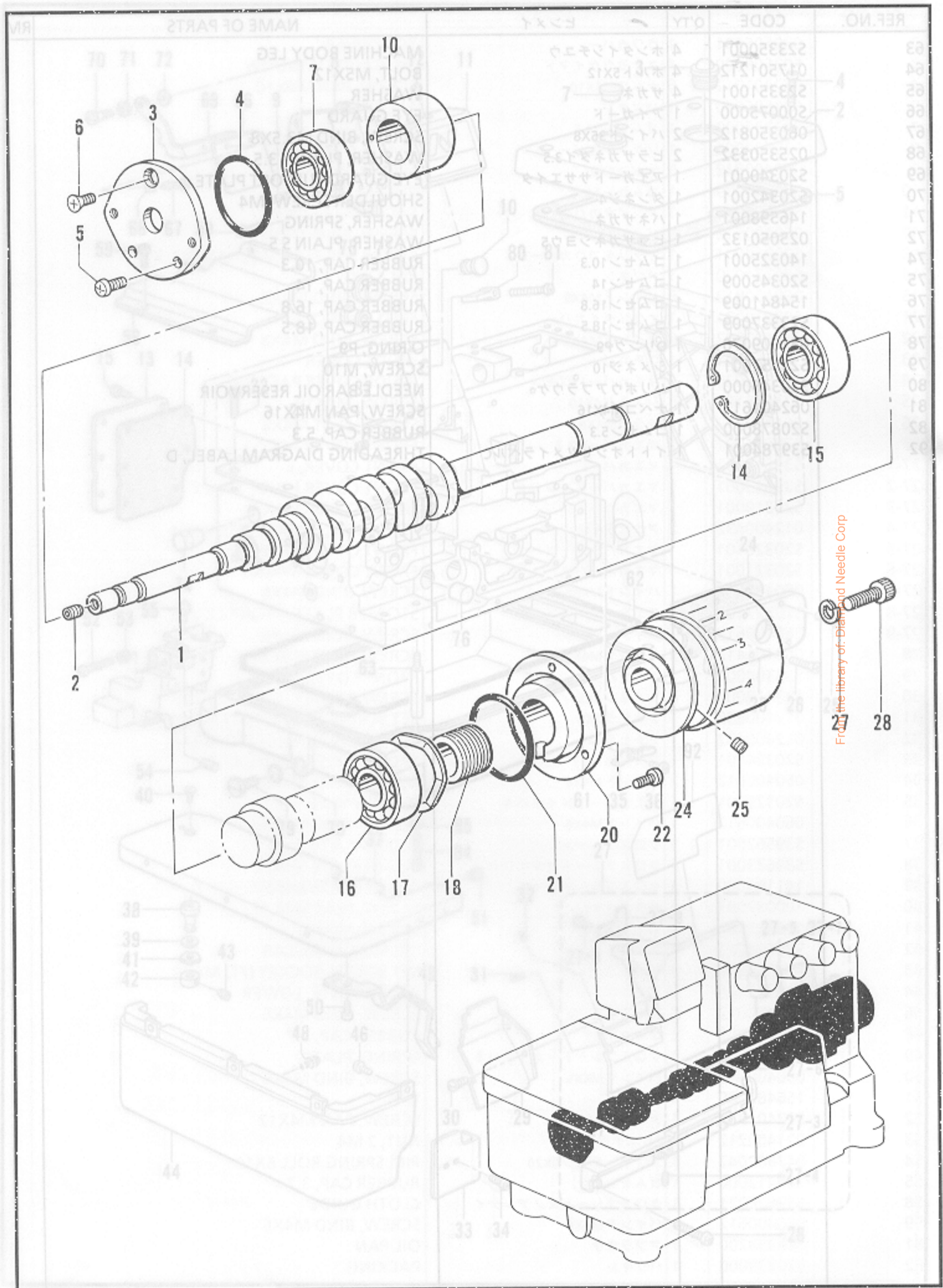

From the library of: Diamond Needle Corp

B. 駆動軸関係 / Crank shaft mechanism / Kurbelwelle / Mécanisme de vilebrequin / Mecanismo del cigüeñal

REF.NO.	CODE	Q'TY	ヒンメイ	NAME OF PARTS	RM
2	012060632	1	アナヒラ6X6	SET SCREW, SOCKET (FT) M6X6	
3	S39629021	1	ベアリングフタ	BEARING CAP	
4	081031870	1	Oリング S31.5	O RING S31.5	
5	062400812	2	ナベコ4X8	SCREW, PAN M4X8	
6	061400812	1	サラコM4X8	SCREW, FLAT M4X8	
7	072600000	1	タマジクウケ6000	BALL BEARING, 6000	
10	S39630000	1	クドウジクメタル	CRANK SHAFT BUSH	
14	048400242	1	トメワアナヨウC40	RETAINING RING, C40	
15	076203000	1	タマジクウケ6203	BALL BEARING, 6203	
16	S27868001	1	タマジクウケ6203V	BALL BEARING, 6203V	
17	S20361001	1	ナミバネ	SPRING, WAVE	
18	S20362101	1	クドウジクオイルキリ	CRANK SHAFT OIL REJECTOR	
20	S39631000	1	ベアリングオサエ	BEARING PRESSER	
21	S20353000	1	Oリング	O RING	
22	062401012	3	ナベコM4X10	SCREW, PAN M4X10	
24-1	S39775001	1	プーリ	PULLEY	
25	012060632	1	アナヒラ6X6	SET SCREW, SOCKET (FT) M6X6	
27	028060242	1	バネザガネ2-6	WASHER, SPRING 2-6	
28-1	018062532	1	アナホルト6X25	BOLT, SOCKET M6X25	
24-2	S39565001	1	プーリ	PULLEY	
1-1	S39759001	1	クドウジクOHクミ "ハイリフト用" <22~25,27,28,33,34,37,38,41,42,45,46,49>	CRANK SHAFT, OH ASSY FOR "HIGH-LIFT"	
1-2	S39760001	1	クドウジクOEクミ "超ハイリフト用" <31, 32, 57>	CRANK SHAFT, OE ASSY FOR "EXTRA HIGH-LIFT"	
35	S39638011	1	ハリクラシフトクミH <RED>	NEEDLE DRIVING CRANK ROD ASSY <RED>	
35	S39638012	1	ハリクラシフトクミH <BLUE>	NEEDLE DRIVING CRANK ROD ASSY <BLUE>	
35-1	018401622	2	ボルト4X16	BOLT, SOCKET M4X16	
35-2	S23342001	2	アナトガリ4X5	SET SCREW, SOCKET (CN) M4X5	
35-3-1	017061612	2	ボルト6X16	BOLT, M6X16	
35-3-2	118735002	2	ワッシャー	WASHER IS	
36	S39641011	1	ハリクラシフトクミE <RED>	NEEDLE DRIVING CRANK ROD ASSY <RED>	
36	S39641012	1	ハリクラシフトクミE <BLUE>	NEEDLE DRIVING CRANK ROD ASSY <BLUE>	
36-1	018401622	2	ボルト4X16	BOLT, SOCKET M4X16	
36-2	S23342001	2	アナトガリ4X5	SET SCREW, SOCKET (CN) M4X5	
36-3-1	017061612	2	ボルト6X16	BOLT, M6X16	
36-3-2	118735002	2	ワッシャー	WASHER	

From the library of: Diamond Needle Corp

C. 針棒関係 / Needle bar mechanism / Nadelstangenvorrichtung  
 / Mécanisme de la barre à aiguille / Mecanismo de la barra de aguja

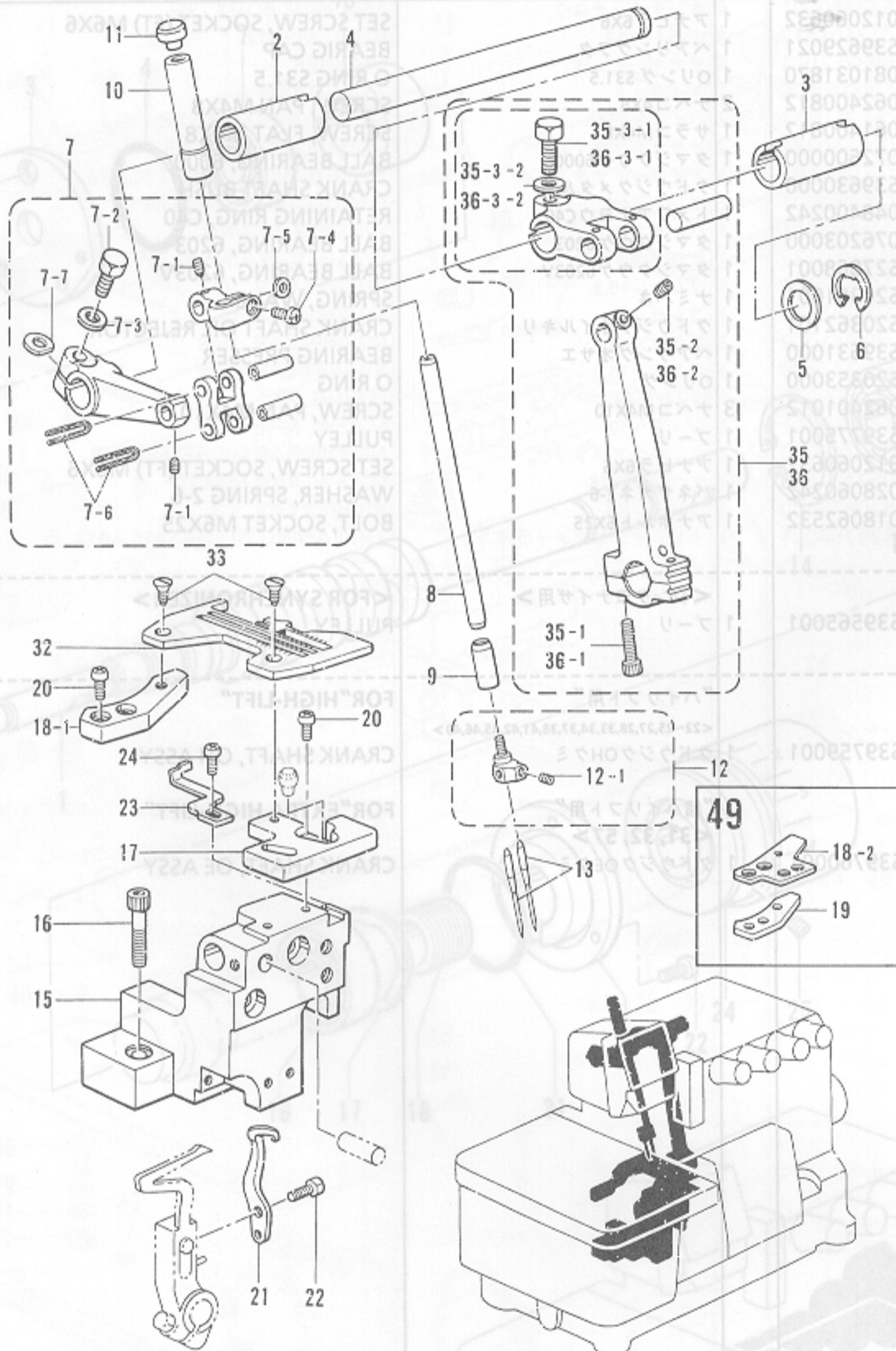

From the library of: Diamond Needle Corp

☆ 駆動軸とロッドは、同色 (赤色・青色の2種類) の組合せで選択組付けをしています。

ご注文の際には色を確認の上、部品コードを指定して下さい。

☆ The crank shaft and rod are to be selected and installed to parts of the same color (2 types; red and blue).

Be sure to check the color before specifying the part no.

☆ Die Kurbelwelle und die Stange müssen mit Teilen der gleichen Farbe kombiniert werden (zwei Typen; rot und blau).

Vor dem Angeben der Teilenummer muß daher die Farbe kontrolliert werden.

☆ Le vilebrequin et la bielle doivent être choisis et montés sur des pièces de la même couleur (2 types; rouge et vert).

Veiller à bien vérifier la couleur avant d'indiquer le code numéroté de pièce.

☆ El cigüeñal y la varilla se deben seleccionar e instalar con las piezas del mismo color (dos tipos; rojas y azules).

Antes de especificar el código de pieza se debe verificar el color.

C. 針棒関係 / Needle bar mechanism / Nadelstangenvorrichtung  
 / Mécanisme de la barre à aiguille / Mecanismo de la barra de aguja

REF.NO.	CODE	Q'TY	ヒンメイ	NAME OF PARTS	RM
2	S39644021	1	ハリジクメタルL	NEEDLE SHAFT BUSH, L	
3	S39645021	1	ハリジクメタルR	NEEDLE SHAFT BUSH, R	
4	S39646021	1	ハリジク	NEEDLE SHAFT	
5	S39647000	1	ザガネ	WASHER	
6	146293001	1	トメワE10	RETAINING RING, E10	
7	S39566001	1	ハリボウダキクミ	NEEDLE BAR CLAMP ASSY	
7-1	S23342001	2	アナトガリ4X5	SET SCREW, SOCKET (CN) M4X5	
7-2	017061612	1	ボルト6X16	BOLT, M6X16	
7-3	118735002	1	ザガネ	WASHER	
7-4	062350812	1	ナベコ3.5X8	SCREW, PAN M3.5X8	
7-5	S20391001	1	スペーサ	SPACER	
7-6	S20392000	2	フェルト	FELT	
7-7	155162001	1	スペーサ	SPACER	
8	S39574001	1	ハリボウ	NEEDLE BAR	
9	S39648021	1	ハリボウメタルD	NEEDLE BAR BUSH, D	
10	S39571021	1	ハリボウメタルU	NEEDLE BAR BUSH, U	
11	104450101	1	ゴムセン8	RUBBER CAP, 8	
12	※	1	ハリドメクミ	NEEDLE CLAMP ASSY	
12-1	146427001	2	アナトメネジ3.18クボミ	SET SCREW, SOCKET (CP) SM3.18	
13	※	2	ミシンハリDCX27	NEEDLE DCX27	
15	S39649021	1	ハリイタササエダイ	NEEDLE PLATE SUPPORT BRACKET	
16	018062532	2	アナホルト6X25	BOLT, SOCKET M6X25	
17-1	S39650051	1	ハリイタササエイタF	NEEDLE PLATE SUPPORT, F	
18-1	S39652021	1	ハリイタササエイタB	NEEDLE PLATE SUPPORT, B	
20	062401012	4	ナベコM4X10	SCREW, PAN M4X10	
21	S20415101	1	イドウハリウケ	MOVABLE NEEDLE GUARD	
22	S20416101	1	ボルト3.5X10	BOLT, M3.5X10	
23	S39653051	1	ハリウケF	NEEDLE GUARD, F	
24	062350612	1	ナベコM3.5X6	SCREW, PAN M3.5X6	
32	※	1	ハリイタ	NEEDLE PLATE	
33	100032003	2	サラネジ4.37	SCREW, FLAT SM4.37	
-----					
17-2	S39651051	1	ハリイタササエイタF	NEEDLE PLATE SUPPORT, F	
18-2	S39768001	1	ハリイタササエイタB	NEEDLE PLATE SUPPORT, B	
19	S39767021	1	ハリイタササエイタBササエ	PLATE, B SUPPORT	
22	S20495001	1	"ハイリフト用"	FOR "HIGH-LIFT"	
35	S39638011	1	ハクリャンクロッドクミH	NEEDLE DRIVING CRANK ROD ASSY	☆
35	S39638012	1	ハクリャンクロッドクミH	NEEDLE DRIVING CRANK ROD ASSY	☆
35-1	018401622	2	アナボルト4X16	BOLT, SOCKET M4X16	
35-2	S23342001	1	アナトガリ4X5	SET SCREW, SOCKET (CN) M4X5	
35-3-1	017061612	1	ボルト6X16	BOLT, M6X16	
35-3-2	118735002	1	ザガネ	WASHER	
-----					
36	S39641011	1	ハクリャンクロッドクミE	NEEDLE DRIVING CRANK ROD ASSY	☆
36	S39641012	1	ハクリャンクロッドクミE	NEEDLE DRIVING CRANK ROD ASSY	☆
36-1	018401622	2	アナボルト4X16	BOLT, SOCKET M4X16	
36-2	S23342001	1	アナトガリ4X5	SET SCREW, SOCKET (CN) M4X5	
36-3-1	017061612	1	ボルト6X16	BOLT, M6X16	
36-3-2	118735002	1	ザガネ	WASHER	

From the library of: Diamond Needle Corp



D. 押工関係 / Presser foot mechanism / Stoffdrückerfuß / Mécanisme de pied presseur / Mecanismo de la prensa tela

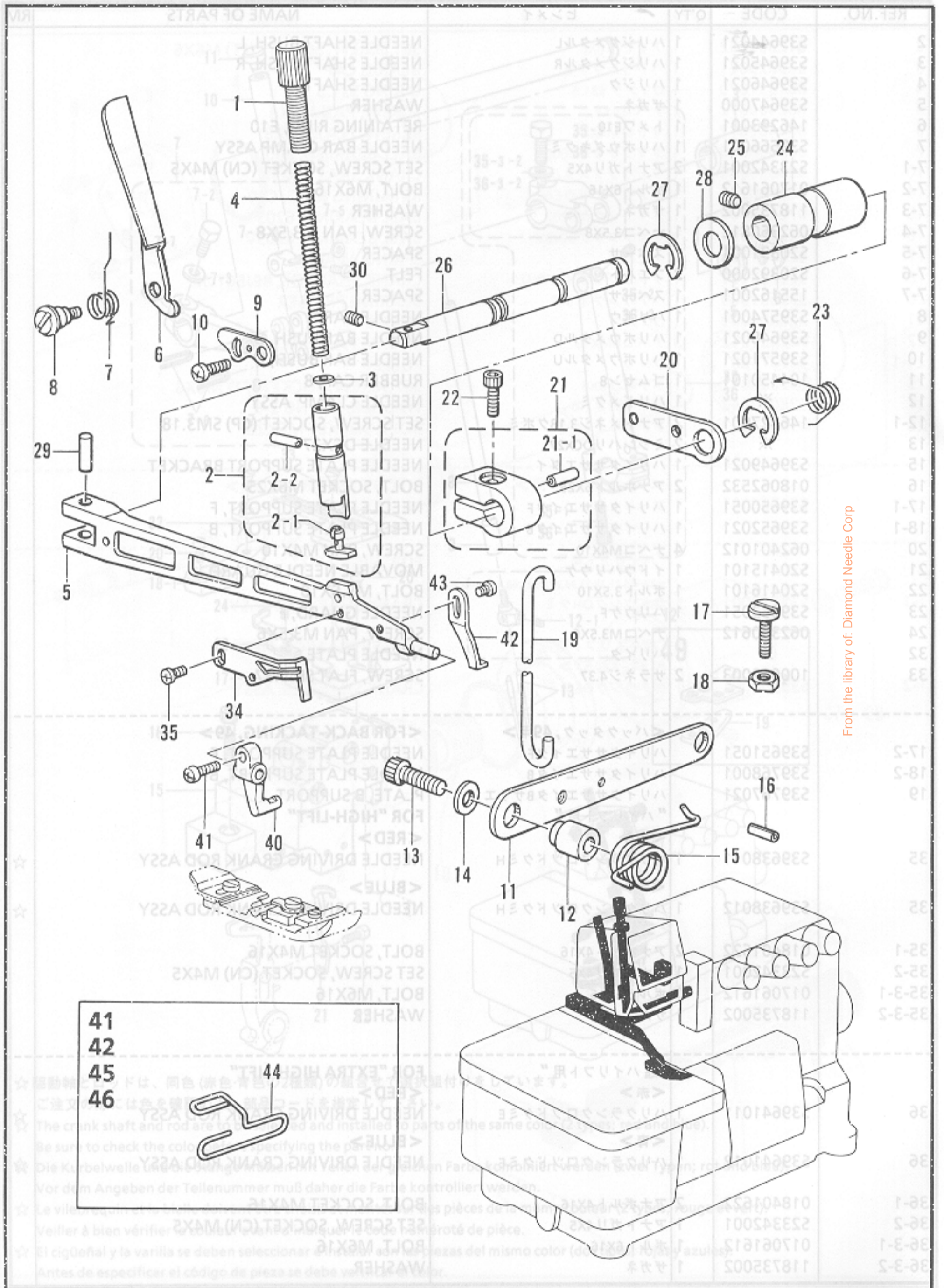

From the library of: Diamond Needle Corp

D. 押工関係 / Presser foot mechanism / Stoffdrückerfuß / Mécanisme de pied presseur / Mecanismo de la prensa tela

REF.NO.	CODE	Q'TY	ヒンメイ	NAME OF PARTS	RM
1	S39658001	1	オサエチヨウセツネジ	PRESSER ADJUST SCREW	
2	S39575001	1	オサエボウクミ	PRESSER BAR ASSY	
2-1	S39577000	1	オサエクツシヨン	CUSHION	
2-2	047301642	1	スプリングピンAW3	PIN, SPRING ROLL AW3	
3	105161004	1	ザガネ	WASHER	
4	S20476001	1	オサエバネ	PRESSER SPRING	
5	S38308021	1	シユオサエウデ	MAIN PRESSER ARM	
6	S39659021	1	オサエテアゲ	PRESSER BAR LIFTER	
7	S39660001	1	オサエテアゲバネ	PRESSER BAR LIFTER SPRING	
8	S39661001	1	ダンネジ4	SHOULDER SCREW, M4	
9	S39662001	1	シユオサエウデストツバ	MAIN PRESSER ARM STOPPER	
10	060400612	1	バインドM4X6	SCREW, BIND M4X6	
11	S39663021	1	オサエアジアゲレバー	PRESSER FOOT LIFTER LEVER	
12	S39664001	1	オサエアジアゲレバーカラー	COLLAR	
13	018062532	1	アナホルト6X25	BOLT, SOCKET M6X25	
14	025060332	1	ヒラザガネダイ6	WASHER, PLAIN L 6	
15	S39665001	1	オサエアジアゲレバーバネ	SPRING	
16	047503242	1	スプリングピンAW5	PIN, SPRING ROLL AW5	
17	S39770001	1	シメネジ4	SCREW, M4	
18	021400212	1	2シユナツト4	NUT, 2 M4	
19	S20485001	1	オサエアゲリンク	PRESSER BAR LIFTER LINK	
20	S39666001	1	オサエアゲレバー	PRESSER BAR LIFTER LEVER	
21	S39667021	1	オサエアゲウデクミ	PRESSER BAR LIFTER ARM ASSY	
21-1	047401442	1	スプリングピンAW4	PIN, SPRING ROLL AW4	
22	018061632	1	アナボルト6X16	BOLT, M6X16	
23	S39669001	1	オサエアゲレバーバネ	SPRING	
24	S39670000	1	オサエウデジクメタル	PRESSER ARM SHAFT BUSH	
25	012060632	1	アナヒラ6X6	SET SCREW, SOCKET (FT) M6X6	
26	S39671021	1	オサエウデジク	PRESSER ARM SHAFT	
27	048090342	2	トメワE9	RETAINING RING, E9	
28	S30562000	1	ザガネ	WASHER	
29	S39672001	1	オサエウデピン	PRESSER ARM PIN	
30	012400432	1	アナヒラ4X4	SET SCREW, SOCKET (FT) M4X4	
34	S37070121	1	フィンガーガードV	FINGER GUARD, V	
35	060300412	1	バインドM3X4	SCREW, BIND M3X4	
40	S20494001	1	フクオサエウデ	SUB PRESSER ARM	
41	062670712	1	ナベコ357-40X7	SCREW, PAN SM3.57-40X7	
42	S20495001	1	オサエストツバ	PRESSER FOOT STOPPER	
43	060300612	1	バインド M3X6	SCREW, BIND M3X6	
-----					
44	S23364000	1	<テープ付け用> テープアンナイ	<FOR TAPING> TAPE GUIDE	
50-5-1	S19286001	1	ツメ	STITCH TONGUE	
50-5-2	S19496001	1	オサエトリツケイタ	PRESSER FOOT PLATE	
50-5-3	150755001	1	シメネジ3.18	SCREW, SM3.18	
50-5-4	S19258001	1	オサエB	PRESSER FOOT, B	
50-5-5	S01295001	1	シメネジ2.38X3.5	SCREW, SM2.38X3.5	
50-5-6	S19259001	1	オサエB	PRESSER FOOT, B	
50-5-7	140530002	1	シメネジ2.38	SCREW, SM2.38	
-----					
50-6	S19287201	1	オサエA	PRESSER FOOT ASSY	
50-6-1	S19976001	1	ツメ	STITCH TONGUE	
50-6-2	S19496001	1	オサエトリツケイタ	PRESSER FOOT PLATE	
50-6-3	150755001	1	シメネジ3.18	SCREW, SM3.18	
50-6-6	S19259001	1	オサエB	PRESSER FOOT, B	
50-6-7	140530002	1	シメネジ2.38	SCREW, SM2.38	

From the library of: Diamond Needle Corp

D. 押工関係 / Presser foot mechanism / Stoffdrückerfuß / Mécanisme de pied presseur / Mecanismo de la prensa tela

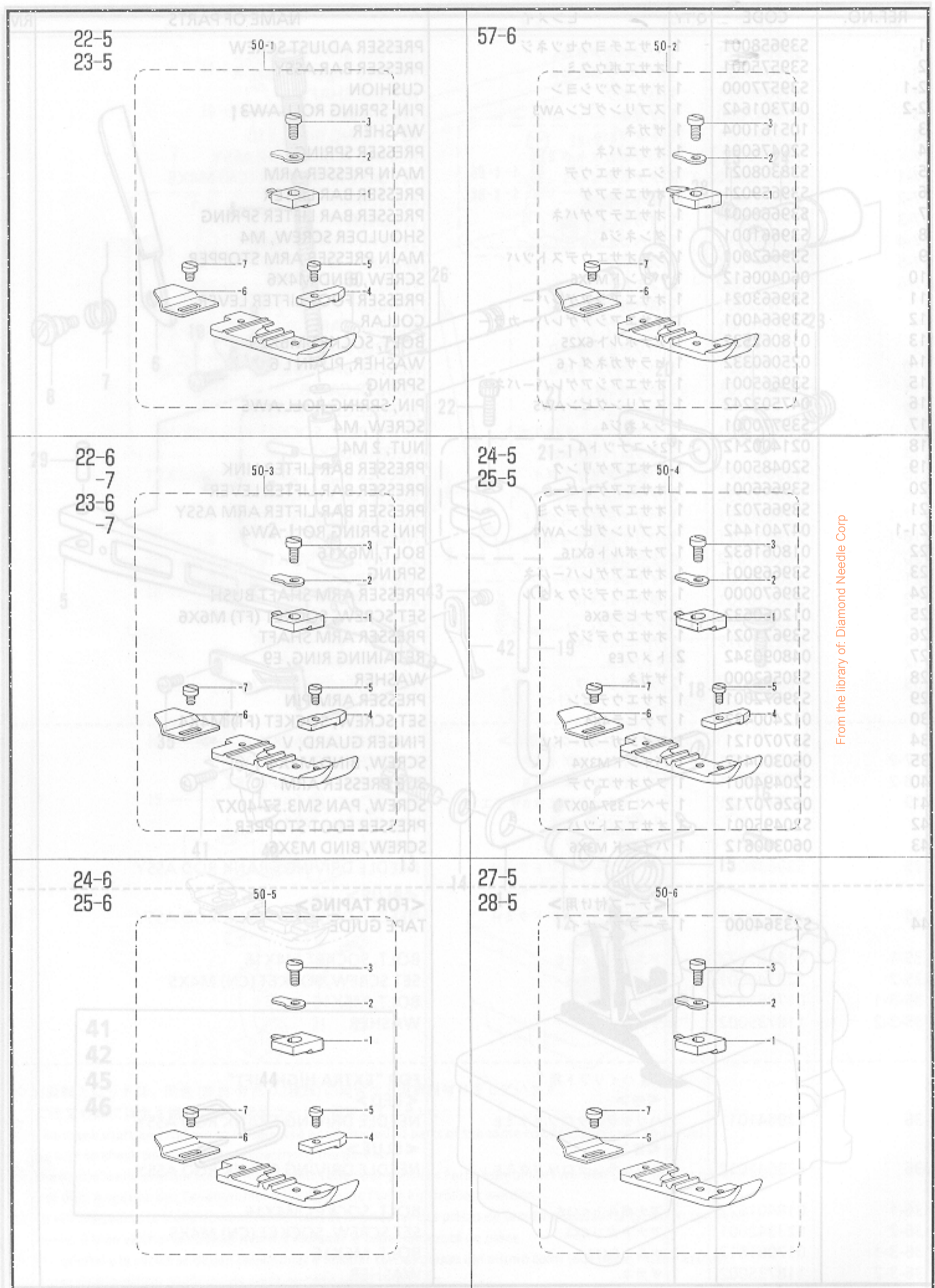

From the library of: Diamond Needle Corp

D. 押工関係 / Presser foot mechanism / Stoffdrückerfuß / Mécanisme de pied presseur  
 / Mecanismo de la prensa tela

REF.NO.	CODE	Q'TY	ヒンメイ	NAME OF PARTS	RM
50-1	S19280001	1	<22-5 23-5> オサエクミ	PRESSER FOOT ASSY	
50-1-1	S19976001	1	ツメ	STITCH TONGUE	
50-1-2	S19496001	1	オサエトリツケイタ	PRESSER FOOT PLATE	
50-1-3	150755001	1	シメネジ3.18	SCREW, SM3.18	
50-1-4	S19258001	1	オサエF	PRESSER FOOT, F	
50-1-5	S01295001	1	シメネジ2.38X3.5	SCREW, SM2.38X3.5	
50-1-6	S19259001	1	オサエB	PRESSER FOOT, B	
50-1-7	140530002	1	シメネジ2.38	SCREW, SM2.38	
50-9-1	S19496001	1	<57-6> ツケイタ	PRESSER FOOT PLATE	
50-2-2	S19303201	1	オサエクミ	PRESSER FOOT ASSY	
50-2-1	S19286001	1	ツメ	STITCH TONGUE	
50-2-2	S19496001	1	オサエトリツケイタ	PRESSER FOOT PLATE	
50-2-3	150755001	1	シメネジ3.18	SCREW, SM3.18	
50-2-6	S19259001	1	オサエB	PRESSER FOOT, B	
50-2-7	140530002	1	シメネジ2.38	SCREW, SM2.38	
50-10-2	S19496001	1	<22-6,7 23-6,7> ツメ	PRESSER FOOT PLATE	
50-3-3	S19282001	1	オサエクミ	PRESSER FOOT ASSY	
50-3-1-4	S19283001	1	ツメ	STITCH TONGUE	
50-3-2-5	S19496001	1	オサエトリツケイタ	PRESSER FOOT PLATE	
50-3-3-6	150755001	1	シメネジ3.18	SCREW, SM3.18	
50-3-4-7	S19258001	1	オサエF	PRESSER FOOT, F	
50-3-5	S01295001	1	シメネジ2.38X3.5	SCREW, SM2.38X3.5	
50-3-6	S19259001	1	オサエB	PRESSER FOOT, B	
50-3-7	140530002	1	シメネジ2.38	SCREW, SM2.38	
50-11-2	S19496001	1	<24-5 25-5> ツメ	PRESSER FOOT PLATE	
50-4-1-3	S19284001	1	オサエクミ	PRESSER FOOT ASSY	
50-4-1-4	S19976001	1	ツメ	STITCH TONGUE	
50-4-2-5	S19496001	1	オサエトリツケイタ	PRESSER FOOT PLATE	
50-4-3-6	150755001	1	シメネジ3.18	SCREW, SM3.18	
50-4-4-7	S19258001	1	オサエF	PRESSER FOOT, F	
50-4-5-8	S01295001	1	シメネジ2.38X3.5	SCREW, SM2.38X3.5	
50-4-6-9	S19259001	1	オサエB	PRESSER FOOT, B	
50-4-7	140530002	1	シメネジ2.38	SCREW, SM2.38	
50-12-1	S19301001	1	<24-6 25-6> オサエクミ	PRESSER FOOT ASSY	
50-5-2-1	S19285001	1	オサエクミ	PRESSER FOOT ASSY	
50-5-1-2	S19286001	1	ツメ	STITCH TONGUE	
50-5-2-3	S19496001	1	オサエトリツケイタ	PRESSER FOOT PLATE	
50-5-3-4	150755001	1	シメネジ3.18	SCREW, SM3.18	
50-5-4-5	S19258001	1	オサエF	PRESSER FOOT, F	
50-5-5-6	S01295001	1	シメネジ2.38X3.5	SCREW, SM2.38X3.5	
50-5-6-7	S19259001	1	オサエB	PRESSER FOOT, B	
50-5-7-8	140530002	1	シメネジ2.38	SCREW, SM2.38	
50-12-9	026250136	1	ヒラサガネコガタ2.6	WASHER, PLAIN S 2.6	
50-6	S19287201	1	<27-5 28-5> オサエクミ	PRESSER FOOT ASSY	
50-6-1	S19976001	1	ツメ	STITCH TONGUE	
50-6-2	S19496001	1	オサエトリツケイタ	PRESSER FOOT PLATE	
50-6-3	150755001	1	シメネジ3.18	SCREW, SM3.18	
50-6-6	S19259001	1	オサエB	PRESSER FOOT, B	
50-6-7	140530002	1	シメネジ2.38	SCREW, SM2.38	

From the library of: Diamond Needle Corp

REF. NO.	CODE	QTY	NAME OF PARTS
50-1	21928007	1	SCREW, SM2.38
50-1-1	21928001	1	SCREW, SM3.18
50-1-2	21949601	1	SCREW, SM2.38X3.2
50-1-3	12025201	1	SCREW, SM2.38
50-1-4	21928001	1	SCREW, SM2.38
50-1-5	20129201	1	SCREW, SM2.38X3.2
50-1-6	21928001	1	SCREW, SM2.38
50-1-7	14023002	1	SCREW, SM2.38
50-2	219303201	1	SCREW, SM2.38
50-2-1	21928001	1	SCREW, SM2.38
50-2-2	21949601	1	SCREW, SM2.38X3.2
50-2-3	12025201	1	SCREW, SM2.38
50-2-6	21928001	1	SCREW, SM2.38
50-2-7	14023002	1	SCREW, SM2.38
50-3	219282001	1	SCREW, SM2.38
50-3-1	219283001	1	SCREW, SM2.38
50-3-2	21949601	1	SCREW, SM2.38X3.2
50-3-3	12025201	1	SCREW, SM2.38
50-3-4	21928001	1	SCREW, SM2.38
50-3-5	20129201	1	SCREW, SM2.38X3.2
50-3-6	21928001	1	SCREW, SM2.38
50-3-7	14023002	1	SCREW, SM2.38
50-4	21928001	1	SCREW, SM2.38
50-4-1	21928001	1	SCREW, SM2.38
50-4-2	21949601	1	SCREW, SM2.38X3.2
50-4-3	12025201	1	SCREW, SM2.38
50-4-4	21928001	1	SCREW, SM2.38
50-4-5	20129201	1	SCREW, SM2.38X3.2
50-4-6	21928001	1	SCREW, SM2.38
50-4-7	14023002	1	SCREW, SM2.38
50-5	21928001	1	SCREW, SM2.38
50-5-1	21928001	1	SCREW, SM2.38
50-5-2	21949601	1	SCREW, SM2.38X3.2
50-5-3	12025201	1	SCREW, SM2.38
50-5-4	21928001	1	SCREW, SM2.38
50-5-5	20129201	1	SCREW, SM2.38X3.2
50-5-6	21928001	1	SCREW, SM2.38
50-5-7	14023002	1	SCREW, SM2.38
50-6	21928001	1	SCREW, SM2.38
50-6-1	21928001	1	SCREW, SM2.38
50-6-2	21949601	1	SCREW, SM2.38X3.2
50-6-3	12025201	1	SCREW, SM2.38
50-6-6	21928001	1	SCREW, SM2.38
50-6-7	14023002	1	SCREW, SM2.38
27-6			SCREW, SM2.38
27-7			SCREW, SM2.38
28-6			SCREW, SM2.38
28-7			SCREW, SM2.38
33-5			SCREW, SM2.38
34-5			SCREW, SM2.38
41-5			SCREW, SM2.38
42-5			SCREW, SM2.38
45-5			SCREW, SM2.38
46-5			SCREW, SM2.38
45-6			SCREW, SM2.38
46-6			SCREW, SM2.38
46-7			SCREW, SM2.38

From the library of: Diamond Needle Corp

D. 押工関係 / Presser foot mechanism / Stoffdrückerfuß / Mécanisme de pied presseur  
 / Mecanismo de la prensa tela

REF.NO.	CODE	Q'TY	ヒンメイ	NAME OF PARTS	RM
50-7	S19288201	1	<27-6,7 28-6,7> オサエクミ	PRESSER FOOT ASSY	
50-7-1	S19283001	1	ツメ	STITCH TONGUE	
50-7-2	S19496001	1	オサエトリツケイタ	PRESSER FOOT PLATE	
50-7-3	150755001	1	シメネジ3.18	SCREW, SM3.18	
50-7-6	S19259001	1	オサエB	PRESSER FOOT, B	
50-7-7	140530002	1	シメネジ2.38	SCREW, SM2.38	
50-9	S19291001	1	<33-5 34-5> オサエクミ	PRESSER FOOT ASSY	
50-9-1	S19496001	1	オサエトリツケイタ	PRESSER FOOT PLATE	
50-9-2	106640001	1	シメネジ3.18	SCREW, SM3.18	
50-9-3	S19259001	1	オサエB	PRESSER FOOT, B	
50-9-4	140530002	1	シメネジ2.38	SCREW, SM2.38	
50-10	S19293001	1	<41-5 42-5> オサエクミ	PRESSER FOOT ASSY	
50-10-1	S19974001	1	ツメ	STITCH TONGUE	
50-10-2	S19496001	1	オサエトリツケイタ	PRESSER FOOT PLATE	
50-10-3	150755001	1	シメネジ3.18	SCREW, SM3.18	
50-10-4	S19296001	1	テープガイド	TAPE GUIDE	
50-10-5	105288001	1	シメネジ2.38	SCREW, SM2.38	
50-10-6	S19259001	1	オサエB	PRESSER FOOT, B	
50-10-7	140530002	1	シメネジ2.38	SCREW, SM2.38	
50-11	S19297001	1	<45-5 46-5> オサエクミ	PRESSER FOOT ASSY	
50-11-1	S19976001	1	ツメ	STITCH TONGUE	
50-11-2	S19496001	1	オサエトリツケイタ	PRESSER FOOT PLATE	
50-11-3	150755001	1	シメネジ3.18	SCREW, SM3.18	
50-11-4	S19279001	1	オサエF	PRESSER FOOT, F	
50-11-5	S19300001	1	テープガイド	TAPE GUIDE	
50-11-6	062630612	1	ナベコ238-56X6	SCREW, PAN SM2.38-56X6	
50-11-7	S19299001	1	オサエB	PRESSER FOOT, B	
50-11-8	140530002	1	シメネジ2.38	SCREW, SM2.38	
50-11-9	026260136	1	ヒラザガネコガタ2.6	WASHER, PLAIN S 2.6	
50-12	S19301001	1	<45-6,7 46-6,7> オサエクミ	PRESSER FOOT ASSY	
50-12-1	S19283001	1	ツメ	STITCH TONGUE	
50-12-2	S19496001	1	オサエトリツケイタ	PRESSER FOOT PLATE	
50-12-3	150755001	1	シメネジ3.18	SCREW, SM3.18	
50-12-4	S19279001	1	オサエF	PRESSER FOOT, F	
50-12-5	S19300001	1	テープガイド	TAPE GUIDE	
50-12-6	062630612	1	ナベコ238-56X6	SCREW, PAN SM2.38-56X6	
50-12-7	S19299001	1	オサエB	PRESSER FOOT, B	
50-12-8	140530002	1	シメネジ2.38	SCREW, SM2.38	
50-12-9	026260136	1	ヒラザガネコガタ2.6	WASHER, PLAIN S 2.6	

From the library of: Diamond Needle Corp

REF. NO.	CODE	QTY	NAME OF PARTS
50-7	219288501	1	SCREW, SM2.38
50-7-1	219283001	1	WASHER PLAIN 2.6
50-7-2	219496001	1	SCREW, SM3.18
50-7-3	150755001	1	SCREW, SM2.38
50-7-6	219259001	1	SCREW, SM2.38
50-7-7	140230002	1	SCREW, SM2.38
50-9	219291001	1	SCREW, SM2.38
50-9-1	219496001	1	SCREW, SM3.18
50-9-2	10664001	1	SCREW, SM2.38
50-9-3	219259001	1	SCREW, SM2.38
50-9-4	140230002	1	SCREW, SM2.38
50-10	219293001	1	SCREW, SM2.38
50-10-1	21924001	1	SCREW, SM2.38
50-10-2	219496001	1	SCREW, SM3.18
50-10-3	150755001	1	SCREW, SM2.38
50-10-4	219296001	1	SCREW, SM2.38
50-10-5	102588001	1	SCREW, SM2.38
50-10-6	219259001	1	SCREW, SM2.38
50-10-7	140230002	1	SCREW, SM2.38
50-11	219297001	1	SCREW, SM2.38
50-11-1	219276001	1	SCREW, SM2.38
50-11-2	219496001	1	SCREW, SM3.18
50-11-3	150755001	1	SCREW, SM2.38
50-11-4	21929001	1	SCREW, SM2.38
50-11-5	21930001	1	SCREW, SM2.38
50-11-6	025630612	1	SCREW, PAN 2.6-5X6
50-11-7	219299001	1	SCREW, SM2.38
50-11-8	140230002	1	SCREW, SM2.38
50-11-9	02560136	1	SCREW, PAN 2.6-5X6
50-12	219301001	1	SCREW, SM2.38
50-12-1	219283001	1	WASHER PLAIN 2.6
50-12-2	219496001	1	SCREW, SM3.18
50-12-3	150755001	1	SCREW, SM2.38
50-12-4	21929001	1	SCREW, SM2.38
50-12-5	21930001	1	SCREW, SM2.38
50-12-6	025630612	1	SCREW, PAN 2.6-5X6
50-12-7	219299001	1	SCREW, SM2.38
50-12-8	140230002	1	SCREW, SM2.38
50-12-9	02560136	1	SCREW, PAN 2.6-5X6
50-13	219288501	1	SCREW, SM2.38
50-14	219283001	1	WASHER PLAIN 2.6
50-15	219296001	1	SCREW, SM2.38
50-17	219296001	1	SCREW, SM2.38
50-18	219301001	1	SCREW, SM2.38
57-7			SCREW, SM2.38
22-4			SCREW, SM2.38
23-4			SCREW, SM2.38
41-6			SCREW, SM2.38
42-6			SCREW, SM2.38
37-5			SCREW, SM2.38
38-5			SCREW, SM2.38
41-5			SCREW, SM2.38
42-5			SCREW, SM2.38
49-5			SCREW, SM2.38
46-6			SCREW, SM2.38

From the library of: Diamond Needle Corp

D. 押工関係 / Presser foot mechanism / Stoffdrückerfuß / Mécanisme de pied presseur  
 / Mecanismo de la prensa tela

REF.NO.	CODE	Q'TY	ヒンメイ	NAME OF PARTS	RM
50-13	S20881201	1	<57-7> オサエクミ	PRESSER FOOT ASSY	
50-13-1	S19975001	1	ツメ	STITCH TONGUE	
50-13-2	S19496001	1	オサエトリツケイタ	PRESSER FOOT PLATE	
50-13-3	150755001	1	シメネジ3.18	SCREW, SM3.18	
50-13-6	S19259001	1	オサエB	PRESSER FOOT, B	
50-13-7	140530002	1	シメネジ2.38	SCREW, SM2.38	
50-19-2	S19496001	1	オサエトリツケイタ	PRESSER FOOT PLATE	
50-19-3	150755001	1	シメネジ3.18	SCREW, SM3.18	
50-19-4	S20881201	1	<37-5 38-5> オサエクミ	PRESSER FOOT ASSY	
50-14	S25538001	1	オサエトリツケイタ	PRESSER FOOT PLATE	
50-14-1	S19496001	1	シメネジ3.18	SCREW, SM3.18	
50-14-2	106640001	1			
50-15	S25543001	1	<22-4 23-4> オサエクミ	PRESSER FOOT ASSY	
50-15-1	S25544001	1	ツメ	STITCH TONGUE	
50-15-2	S19496001	1	オサエトリツケイタ	PRESSER FOOT PLATE	
50-15-3	150755001	1	シメネジ3.18	SCREW, SM3.18	
50-15-4	S19258001	1	オサエF	PRESSER FOOT, F	
50-15-5	S01295001	1	シメネジ2.38X3.5	SCREW, SM2.38X3.5	
50-15-6	S19259001	1	オサエB	PRESSER FOOT, B	
50-15-7	140530002	1	シメネジ2.38	SCREW, SM2.38	
50-21-1	S25544001	1	ツメ	STITCH TONGUE	
50-17	S25546001	1	<41-6 42-6> オサエクミ	PRESSER FOOT ASSY	
50-17-1	S25547001	1	ツメ	STITCH TONGUE	
50-17-2	S19496001	1	オサエトリツケイタ	PRESSER FOOT PLATE	
50-17-3	150755001	1	シメネジ3.18	SCREW, SM3.18	
50-17-4	S19296001	1	テープガイド	TAPE GUIDE	
50-17-5	105288001	1	シメネジ2.38	SCREW, SM2.38	
50-17-6	S19259001	1	オサエB	PRESSER FOOT, B	
50-17-7	140530002	1	シメネジ2.38	SCREW, SM2.38	
50-25	S30898001	1	オサエクミ	PRESSER FOOT ASSY	
50-25-1	S30500001	1	ツメ	STITCH TONGUE	
50-25-2	S01295001	1	シメネジ2.38X3.5	SCREW, SM2.38X3.5	
50-18	S19302001	1	<49-5,6> オサエクミ	PRESSER FOOT ASSY	
50-18-1	S19977001	1	ツメ	STITCH TONGUE	
50-18-2	S19496001	1	オサエトリツケイタ	PRESSER FOOT PLATE	
50-18-3	150755001	1	シメネジ3.18	SCREW, SM3.18	
50-18-4	S19279001	1	オサエF	PRESSER FOOT, F	
50-18-5	060630412	1	バインド238-56X4	SCREW, BIND M2.38-56X4	

From the library of: Diamond Needle Corp



D. 押工関係 / Presser foot mechanism / Stoffdrückerfuß / Mécanisme de pied presseur  
 / Mecanismo de la prensa tela

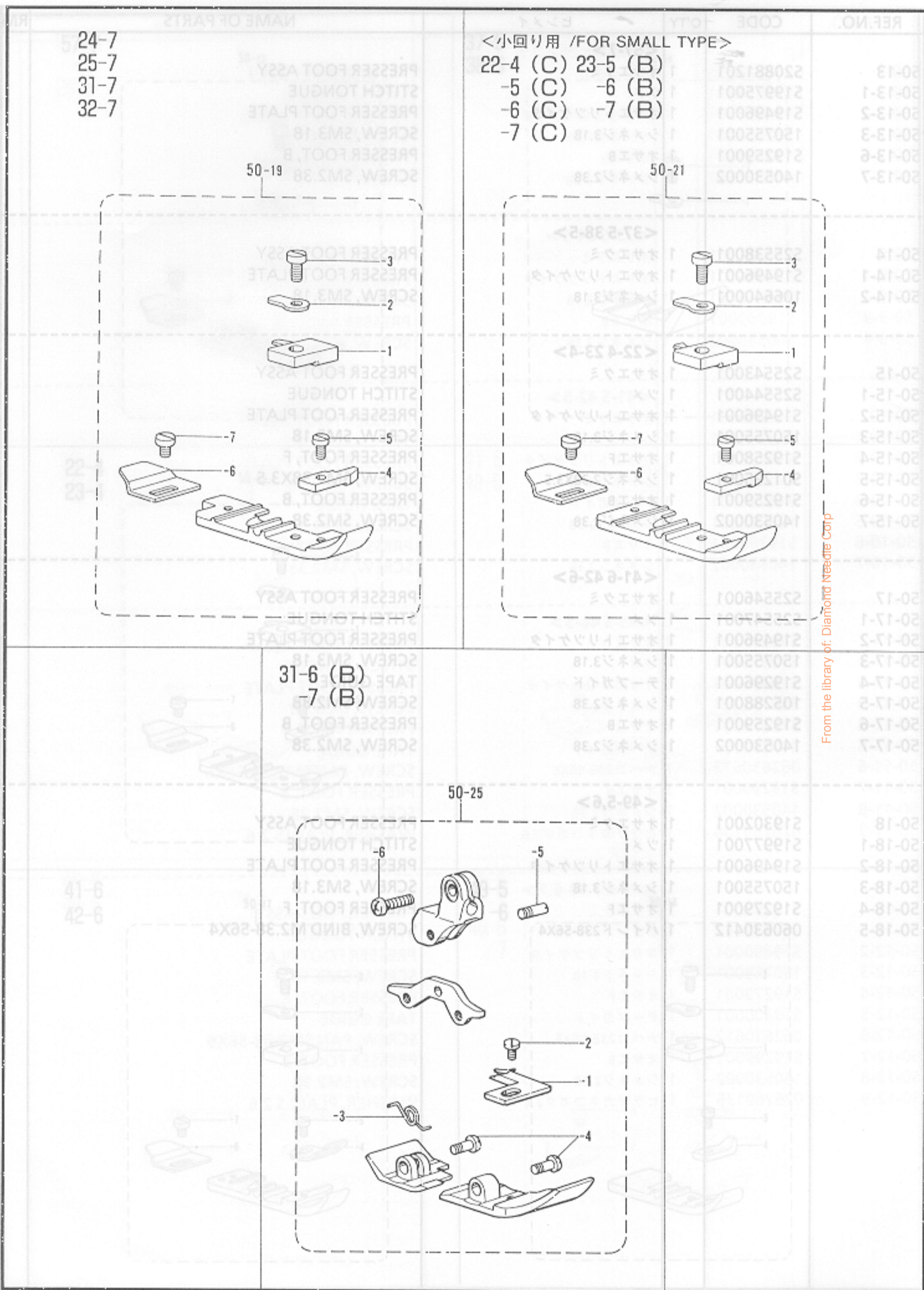

From the library of: Diamond Needle Corp

D. 押工関係 / Presser foot mechanism / Stoffdrückerfuß / Mécanisme de pied presseur  
 / Mecanismo de la prensa tela

REF.NO.	CODE	Q'TY	ヒンメイ	NAME OF PARTS	RM
50-19	S29869001	1	<24-7 25-7 31-7 32-7> オサエクミ	ECCENTRIC WHEEL ASSY PRESSER FOOT ASSY	
50-19-1	S19975001	1	ツメ	STITCH TONGUE	
50-19	S29871001	1	<31-6 32-6> オサエクミ	TWIST SPRING PRESSER FOOT ASSY	
50-19-1	S19286001	1	ツメ	STITCH TONGUE	
50-19-2	S19496001	1	オサエトリツケイタ	PRESSER FOOT PLATE	
50-19-3	150755001	1	シメネジ3.18	SCREW, SM3.18	
50-19-4	S29870001	1	オサエF	PRESSER FOOT, F	
50-19-5	S01295001	1	シメネジ2.38X3.5	SCREW, SM2.38X3.5	
50-19-6	S19259001	1	オサエB	PRESSER FOOT, B	
50-19-7	140530002	1	シメネジ2.38	SCREW, SM2.38	
50-21	S29950001	1	<22-5C,23-5B> オサエクミ	RETAINING RING PRESSER FOOT ASSY	
50-21-1	S19976001	1	ツメ	STITCH TONGUE	
50-21	S29951001	1	<22-6C,7C 23-6B,7B> オサエクミ	FEED SHAFT BUSH, L PRESSER FOOT ASSY	
50-21-1	S19283001	1	ツメ	STITCH TONGUE	
50-21	S29952001	1	<22-4C> オサエクミ	PRESSER FOOT ASSY	
50-21-1	S25544001	1	ツメ	STITCH TONGUE	
50-21-2	S19496001	1	オサエトリツケイタ	PRESSER FOOT PLATE	
50-21-3	150755001	1	シメネジ3.18	SCREW, SM3.18	
50-21-4	S19258001	1	オサエF	PRESSER FOOT, F	
50-21-5	S01295001	1	シメネジ2.38X3.5	SCREW, SM2.38X3.5	
50-21-6	S19259001	1	オサエB	PRESSER FOOT, B	
50-21-7	140530002	1	シメネジ2.38	SCREW, SM2.38	
50-25	S30898001	1	<31-6B,7B> オサエクミ	PRESSER FOOT ASSY	
50-25-1	S30900001	1	ツメ	STITCH TONGUE	
50-25-2	S01295001	1	シメネジ2.38X3.5	SCREW, SM2.38X3.5	
50-25-3	S30902001	1	オサエBネジリバネ	PRESSER FOOT TWIST SPRING	
50-25-4	S30904001	2	オサエFBササエネジ	SCREW, PRESSER FOOT SUPPORT	
50-25-5	S19311101	1	オサエササエネジ	PRESSER FOOT SUPPORT SCREW	
50-25-6	062670712	1	ナベコ357-40X7	SCREW, PAN SM3.57-40X7	
40-1	S39769051	1	カトウウデリンククミ	DIFF. FEED ARM LINK ASSY	
41	S39769051	1	アトボルト6X16	BOLT, M6X16	
42	S39769051	1	ワッシャー	WASHER	
43	S39769051	1	ボルト5X15	BOLT, M5X15	
44	S39769051	1	オクリダイヤモンド	FEED BAR GUIDE COVER	
45	S39769051	1	オクリダイヤモンド	FEED BAR GUIDE, L	
46	S39769051	1	オクリダイヤモンド	FEED BAR GUIDE, R	
47	S39769051	1	ボクシレイタ	FRAGMENT PROTECTOR	
48	S39769051	1	ボクシレイタ	FRAGMENT PROTECTOR	
49	S39769051	1	アトボルト6X14	BOLT, SOCKET M6X14	
50	S39769051	1	ワッシャー	WASHER, PLAIN S4	
51	S39769051	1	ボクシレイタ	DIFFERENTIAL FEED ADJUST LINK	
52	S39769051	1	ボクシレイタ	SCREW, M5	
53	S39769051	1	ボクシレイタ	DIFFERENTIAL LINK LEVER	
54	S39769051	1	ボクシレイタ	BOLT, SOCKET M6X14	
54-1	S39769051	1	ボクシレイタ	DIFF. FEED ADJUST LEVER ASSY	
55	S39769051	1	ボクシレイタ	NUT, ROUND M6	
				SPRING	

From the library of: Diamond Needle Corp

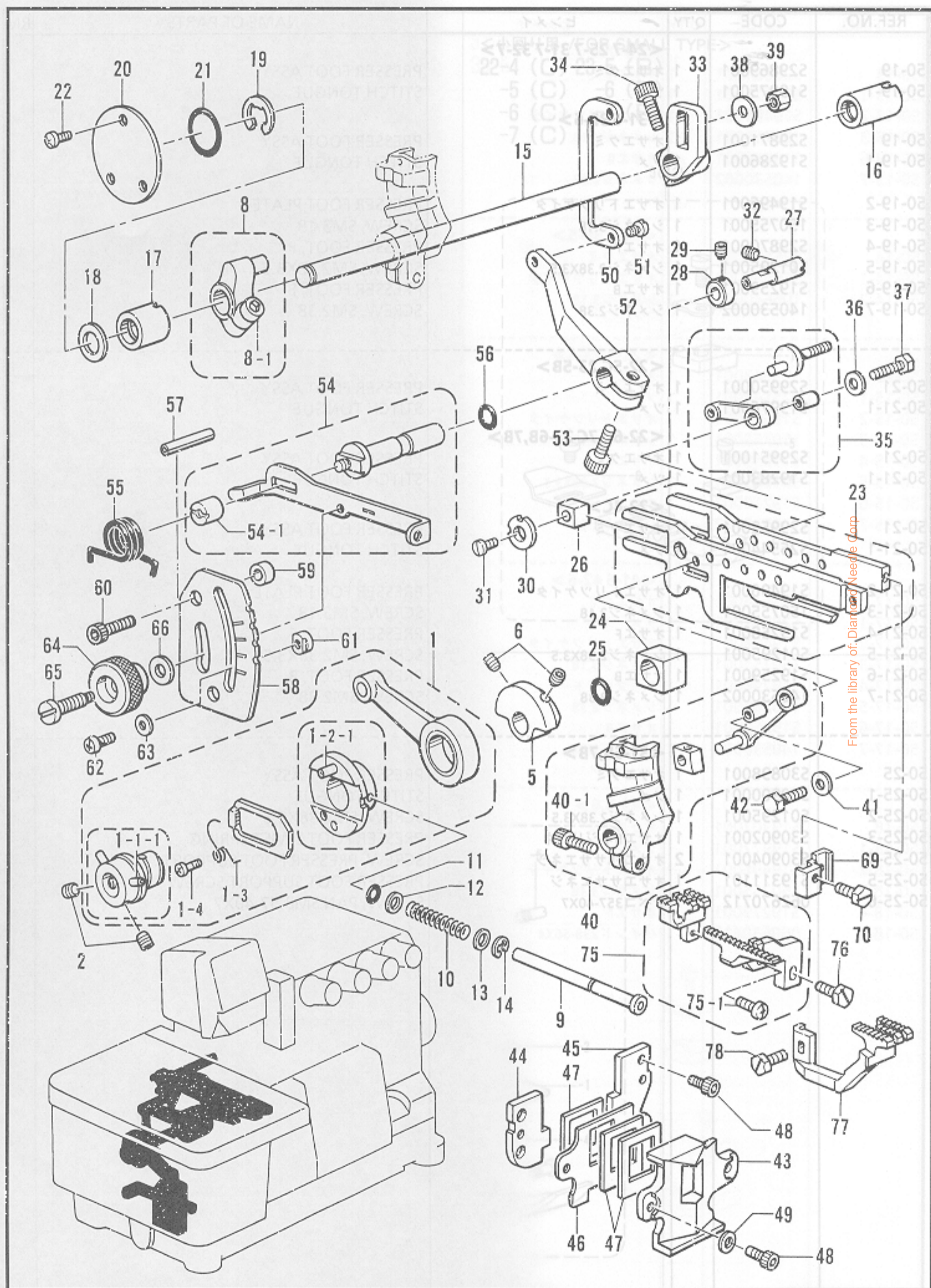

E. 送り関係 / Feed mechanism / Transportvorrichtung / Mécanisme de l'entraînement  
 / Mecanismo de la alimentación

REF.NO.	CODE	QTY	ヒンメイ	NAME OF PARTS	RM
1	S39578001	1	ヘンシンリンクミ	ECCENTRIC WHEEL ASSY	
1-1-1	047301242	2	スプリングピンAW3	PIN, SPRING AW3	
1-2-1	047301242	1	スプリングピンAW3	PIN, SPRING AW3	
1-3	S39585001	1	ラチエツトメネジリバネ	TWIST SPRING	
1-4	S39586001	1	バネトメネジ3	SCREW, M3	
2	012060632	2	アナヒラ6X6	SET SCREW, SOCKET (FT) M6X6	
5	S39673020	1	バランスウエイト	BALANCE WEIGHT	
6	012060632	2	アナヒラ6X6	SET SCREW, SOCKET (FT) M6X6	
8	S39589021	1	オクリウデクミ	FEED ARM ASSY	
8-1	018061632	1	アナボルト6X16	BOLT, M6X16	
9	S39674001	1	オクリチヨウセツボタンジク	FEED ADJUST SHAFT	
10	S39675001	1	ボタンジクバネ	SPRING	
11	081005070	1	OリングP5	O RING, P5	
12	025710232	1	ヒラザガネチユウ4.76	WASHER, PLAIN M 4.76	
13	025710232	1	ヒラザガネチユウ4.76	WASHER, PLAIN M 4.76	
14	048040342	1	トメワE4	RETAINING RING, E4	
15	S39676021	1	オクリジク	FEED SHAFT	
16	S39677021	1	メタル11.11-17	BUSH, 11.11-17	
17	S39678021	1	オクリジクメタルL	FEED SHAFT BUSH, L	
18	S30562000	1	ザガネ	WASHER	
19	048090342	1	トメワE9	RETAINING RING, E9	
20	S39679001	1	オクリジクメタルLフタ	FEED SHAFT BUSH CAP, L	
21	081020070	1	OリングP20	O RING, P20	
22	060400612	3	バインドM4X6	SCREW, BIND M4X6	
23	S39680001	1	オクリダイクミ	FEED BAR ASSY	
24	S38312050	1	ジヨウゲオクリカクゴマ	FEED LIFTING SLIDE BLOCK	
25	081010070	1	OリングP10	O RING, P10	
26	S39683000	1	オクリダイカクゴマ	FEED BAR SLIDE BLOCK	
27	S39684021	1	オクリダイカクコマジク	FEED BAR SLIDE BLOCK SHAFT	
28	S39685001	1	セットカラー	SET SCREW COLLAR	
29	012400432	1	アナヒラ4X4	SET SCREW, SOCKET (FT) M4X4	
30	S20530001	1	ザガネ	WASHER	
31	061350616	1	サラコ35X6	SCREW, FLAT M3.5X6	
32	012400832	1	アナヒラ4X8	SET SCREW, SOCKET (FT) M4X8	
33	S42042021	1	シユオクリウデ	MAIN FEED ARM	
34	018061632	1	アナボルト6X16	BOLT, M6X16	
35	S39773001	1	シユオクリリンククミ	MAIN FEED LINK ASSY	
36	S39690021	1	ザガネ	WASHER	
37	S23360001	1	ボルト5X15	BOLT, M5X15	
38	S02573000	1	ザガネ	WASHER	
39	S39691001	1	ナツト5	NUT, M5	
40	S39769051	1	サドウオクリウデリンククミ	DIFF. FEED ARM LINK ASSY	
40-1	018061632	1	アナボルト6X16	BOLT, M6X16	
41	S39690021	1	ザガネ	WASHER	
42	S23360001	1	ボルト5X15	BOLT, M5X15	
43	S38311100	1	オクリダイアンナイカバー	FEED BAR GUIDE COVER	
44	S39686000	1	オクリダイアンナイL	FEED BAR GUIDE, L	
45	S39687000	1	オクリダイアンナイR	FEED BAR GUIDE, R	
46	S39688001	1	ボウジンイタササエ	FRAGMENT PROTECTOR PLATE	
47	S20526000	3	ボウジンイタ	FRAGMENT PROTECTOR PLATE	
48	018400832	6	アナボルト4X8	BOLT, SOCKET M4X8	
49	025040132	2	ヒラザガネシヨウ4	WASHER, PLAIN S 4	
50	S39692021	1	サドウチヨウセツリンク	DIFFERENTIAL FEED ADJUST LINK	
51	S20543101	1	シメネジ5	SCREW, M5	
52	S20544000	1	サドウリンクレバー	DIFFERENTIAL LINK LEVER	
53	018061432	1	アナボルト6X14	BOLT, SOCKET M6X14	
54	S39593021	1	サドウチヨウセツレバークミ	DIFF. FEED ADJUST LEVER ASSY	
54-1	S39596021	1	マルナツト6	NUT, ROUND M6	
55	S20547001	1	レバーバネ	SPRING	

From the library of: Diamond Needle Corp

E. 送り関係 / Feed mechanism / Transportvorrichtung / Mécanisme de l'entraînement  
 / Mecanismo de la alimentación

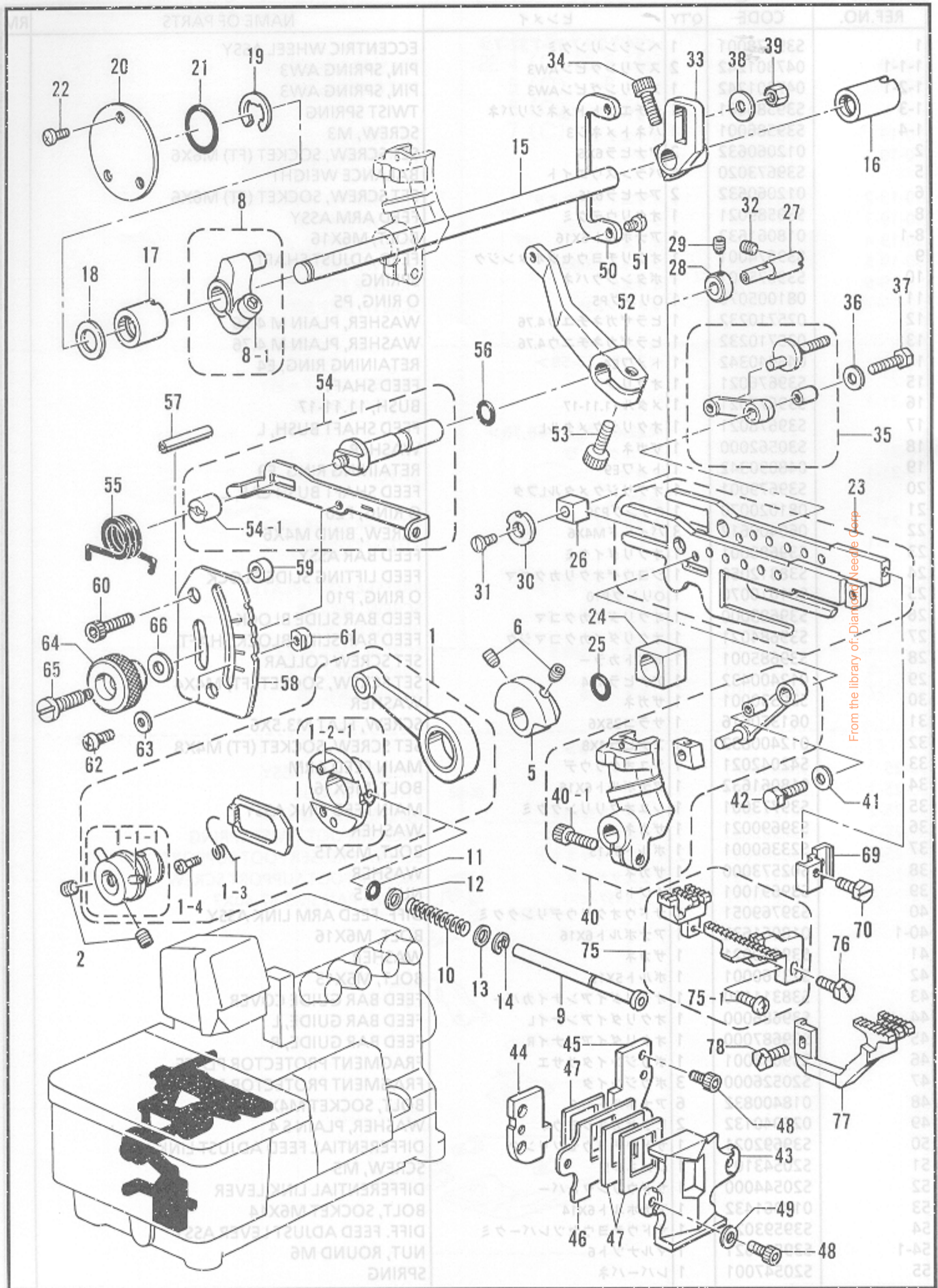

From the library of: Diamond Needle Corp.

E. 送り関係 / Feed mechanism / Transportvorrichtung / Mécanisme de l'entraînement / Mecanismo de la alimentación

REF.NO.	CODE	Q'TY	ヒンメイ	NAME OF PARTS	RM
56	081005670	1	OリングPW5	O RING, PW5	
57	047502242	1	スプリングピンAW5	PIN, SPRING ROLL AW5	
58	S39693001	1	サドウリヨウメモリタ	DIFFERENTIAL STITCH CONTROL	
59	S20548001	2	カラー	COLLAR	
60	018061632	2	アナボルト6X16	BOLT, M6X16	
61	S25818001	2	チヨウセツレバーストツバ	STOPPER FOR ADJUST LEVER	
62	060350812	2	バインド35X8	SCREW, BIND M3.5X8	
63	025350332	2	ヒラザガネダイ3.5	WASHER, PLAIN L 3.5	
64	S39694021	1	セツトネジツマミ	SET SCREW KNOB	
65	S39695001	1	セツトネジ	SET SCREW	
66	S20560001	1	サラバネザガネ	SPRING WASHER	
69	S23628001	1	シユオクリバトリツケダイ	MAIN FEED DOG SET BRACKET	
70	S23621101	1	ボルト35X8	BOLT, M3.5X8	
75	※	1	シユオクリバクミ	MAIN FEED DOG ASSY	
75-1	060630712	1	バインド238-56X7	SCREW, BIND SM2.38-56X7	
76	S23621101	1	ボルト35X8	BOLT, M3.5X8	
77	※	1	サドウオクリバ	DIFFERENTIAL FEED DOG	
78	S23621101	1	ボルト35X8	BOLT, M3.5X8	
26	017500812	1	ボルト5X8	BOLT, M5X8	
27	S20585001	1	シタメストリメ	SPRING	
28	S39709021	1	シタメスバネウケ	SPRING HOLDER	
29	062400812	1	ナベコ4X8	SCREW, PAN M4X8	
30	S39696011	1	ウワメスクランクロッド	UPPER KNIFE CRANK ROD ASSY, O	☆
30	S39696012	1	ウワメスクランクロッドクミ	UPPER KNIFE CRANK ROD ASSY, O	☆
30-1-1	018401622	1	アナボルト6X16	BOLT, SOCKET M4X16	
30-2	S39696012	1	ウワメスクランクロッドクミ	UPPER KNIFE CRANK ROD ASSY, O	
30-2-1	017501612	1	ボルト6X16	BOLT, M6X16	
30-2-2	118735002	1	ザガネ	WASHER	
30-3	S23342001	1	セツトネジソケット	SET SCREW, SOCKET (CN) M4X5	
9-2	S20576001	1	ウワメスダキ	UPPER KNIFE HOLDER	
10-2	062401612	1	ナベコM4X16	SCREW, PAN M4X16	
12	S20577001	1	ウワメスオサエ	UPPER KNIFE PRESSER	
13	S20578101	1	ウワメスオサエイタ	UPPER KNIFE PRESSER PLATE	
14	025030132	1	ヒラザガネシヨウ3	WASHER, PLAIN S 3	
15-2	※	1	カクメス	ANGLE KNIFE	
16-2	062300412	1	ナベコ3X4	SCREW, PAN M3X4	
15-2	S20896101	1	カクメス 幅狭	ANGLE KNIFE, NARROW	
15-2	S20896201	1	カクメス 幅狭 波刃	ANGLE KNIFE, NARROW WAVE EDG	
15-2	S20579101	1	カクメス 幅広	ANGLE KNIFE, WIDE	
15-2	S20896301	1	カクメス 幅広 波刃	ANGLE KNIFE, WIDE WAVE EDGE	

From the library of: Diamond Needle Corp

★ 駆動軸とロッドは、同色(赤・青の2種類)の組合せで選択取り付けをしています。  
 ご注文の際は必ず仕様の上、部品コードを指定して下さい。  
 ★ The crank shaft and rod are to be selected and installed to parts of the same color (2 types; red and blue).  
 Be sure to check the color before specifying the part no.  
 ★ Die Kurbelwelle und die Pleuellstange müssen mit Teilen der gleichen Farbe kombiniert werden (zwei Typen; rot und blau).  
 Vor dem Angben der Teilenummer muß genau die Farbe kontrolliert werden.  
 ★ Le vilebrequin et la bielle doivent être choisis et montés sur des pièces de la même couleur (2 types; rouge et vert).  
 Veillez à bien vérifier la couleur avant d'indiquer le code numéroté de pièce.  
 ★ El cigüeñal y el varillaje se debe seleccionar e instalar con las piezas del mismo color (dos tipos; rojo y azul).

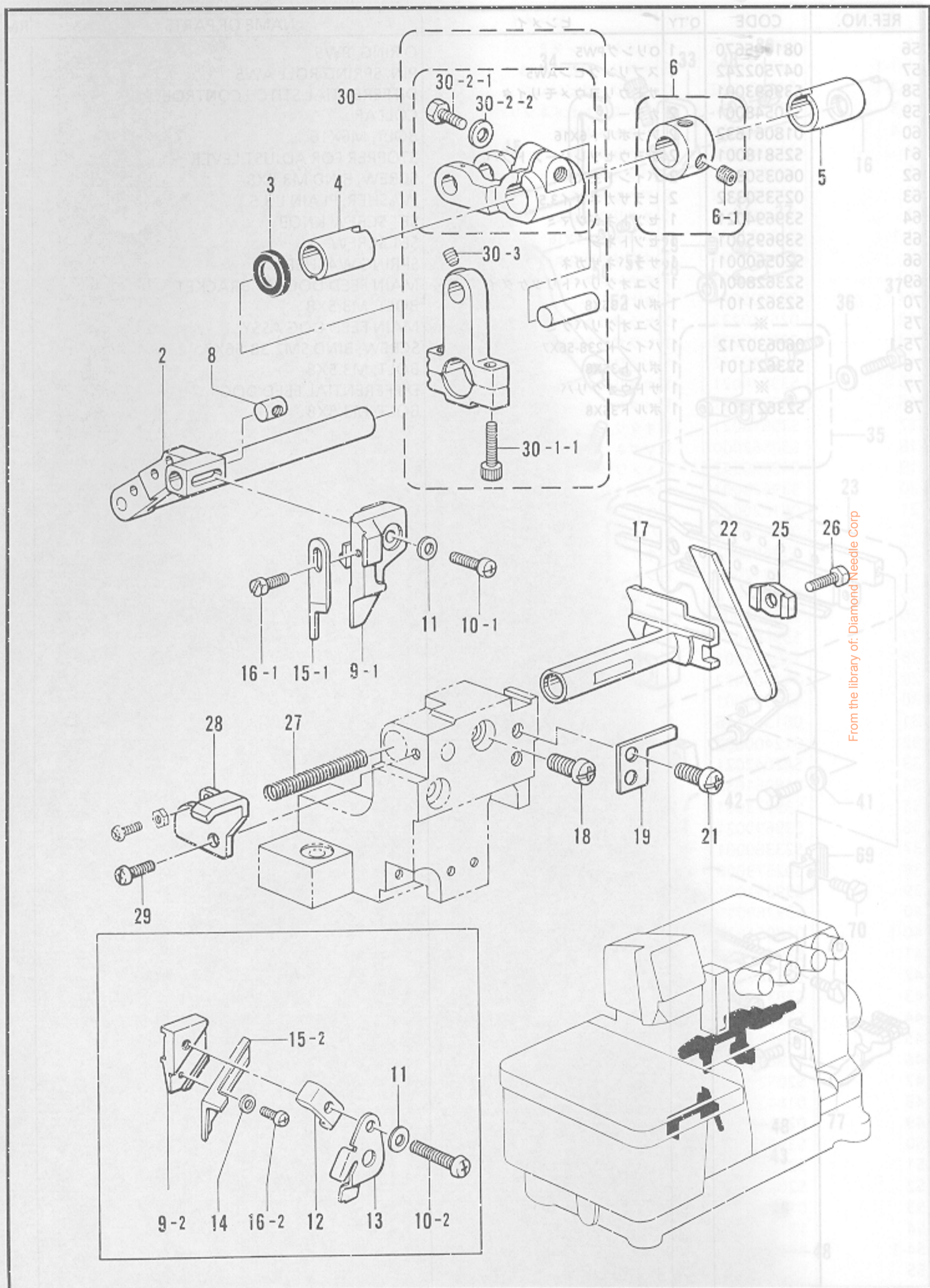

From the library of: Diamond Needle Corp

F. 上メス・下メス関係 / Knife mechanism / Messer / Mécanisme du couteau  
/ Mecanismo de la cuchilla

REF.NO.	CODE	Q'TY	ヒンメイ	NAME OF PARTS	RM
2	S20571101	1	ウワメスサドウウデ	UPPER KNIFE DIFFERENTIAL ARM	
3	155247000	1	ダストシール	DUST SEAL	
4	S39704021	1	ウワメスメタルL	UPPER KNIFE BUSH L	
5	S39677021	1	メタル11.11-17	BUSH, 11.11-17	
6	S43527001	1	セットカラークミ	SET COLLAR ASSY	
6-1	012060632	2	アナヒラ6X6	SET SCREW, SOCKET (FT) M6X6	
8	S20574001	1	ウワメスダキナツト	NUT	
9-1	S20575001	1	ウワメスダキ	UPPER KNIFE HOLDER	
10-1	062401212	1	ナベコ4X12	SCREW, PAN M4X12	
11	025040132	1	ヒラザガネシヨウ4	WASHER, PLAIN S 4	
15-1	144074300	1	ウワメス	UPPER KNIFE	
16-1	S23621101	1	ボルト35X8	BOLT, M3.5X8	
17	S39706001	1	シタメストリツケダイ	LOWER KNIFE HOLDER	
18	062060812	1	ナベコ6X8	SCREW, PAN M6X8	
19	S39707001	1	シタメストリツケダイアンナイ	LOWER KNIFE HOLDER GUIDE	
21	062060812	2	ナベコ6X8	SCREW, PAN M6X8	
22	※	1	シタメス	LOWER KNIFE	
25	S39708001	1	シタメスオサエ	LOWER KNIFE PRESSER	
26	017500812	1	ボルト5X8	BOLT, M5X8	
27	S20585001	1	シタメストリツケダイバネ	SPRING	
28	S39709021	1	シタメスバネウケ	SPRING HOLDER	
29	062400812	1	ナベコ4X8	SCREW, PAN M4X8	
30-1-1-1	S23342001	1	<赤>	<RED>	
30-1-2	S39696011	1	ウワメスクランクロッドクミ	UPPER KNIFE CRANK ROD ASSY, O	☆
30-1-1-3	118735002	1	<青>	<BLUE>	
30-1-4	S39696012	1	ウワメスクランクロッドクミ	UPPER KNIFE CRANK ROD ASSY, O	☆
30-1-2-1	S38320000	1	アナル	OVER LOOPER GUIDE	
30-1-1	018401622	2	アナボルト4X16	BOLT, SOCKET M4X16	
30-2	S39696012	1	ウワメスクランクロッドクミ	UPPER KNIFE CRANK ROD ASSY, O	
30-2-1	017061612	1	ボルト6X16	BOLT, M6X16	
30-2-2	118735002	1	ザガネ	WASHER	
30-3	S23342001	1	アナトガリ4X5	SET SCREW, SOCKET (CN) M4X5	
9-2-1-2	017061612	1	<国内用/オプション>	<FOR BULKY, HEAVY>	
9-2-1-3	S20576001	1	ウワメスダキ	UPPER KNIFE HOLDER	
10-2-4	062401612	1	ナベコM4X16	SCREW, PAN M4X16	
12-2-1	S20577001	1	ウワメスオサエ	UPPER KNIFE PRESSER	
13-2-2	S20578101	1	ウワメスオサエイタ	UPPER KNIFE PRESSER PLATE	
14-3	025030132	1	ヒラザガネシヨウ3	WASHER, PLAIN S 3	
15-2	※	1	カクメス	ANGLE KNIFE	
16-2	062300412	1	ナベコ3X4	SCREW, PAN M3X4	
15-2	S20896101	1	<オプションパーツ>	<OPTION PARTS>	
15-2	S20897101	1	カクメス 幅狭	ANGLE KNIFE, NARROW	
15-2	S20579101	1	カクメス 幅狭 波刃	ANGLE KNIFE, NARROW WAVE EDG	
15-2	S20579101	1	カクメス 幅広	ANGLE KNIFE, WIDE	
15-2	S20898101	1	カクメス 幅広 波刃	ANGLE KNIFE, WIDE WAVE EDGE	

From the library of: Diamond Needle Corp

185-N21-222

☆ 駆動軸とロッドは、同色(赤色・青色の2種類)の組合せで選択組付けをしています。

ご注文の際には色を確認の上、部品コードを指定して下さい。

☆ The crank shaft and rod are to be selected and installed to parts of the same color (2 types; red and blue).

Be sure to check the color before specifying the part no.

☆ Die Kurbelwelle und die Stange müssen mit Teilen der gleichen Farbe kombiniert werden (zwei Typen; rot und blau).

Vor dem Angeben der Teilenummer muß daher die Farbe kontrolliert werden.

☆ Le vilebrequin et la bielle doivent être choisis et montés sur des pièces de la même couleur (2 types; rouge et vert).

Veiller à bien vérifier la couleur avant d'indiquer le code numéroté de pièce.

☆ El cigüeñal y la varilla se deben seleccionar e instalar con las piezas del mismo color (dos tipos; rojas y azules).

Antes de especificar el código de pieza se debe verificar el color.



G. 上ルーパー関係 / Over looper mechanism / Oberen Greifer / Mécanisme du boucleur supérieur / Mecanismo del presilladora superior

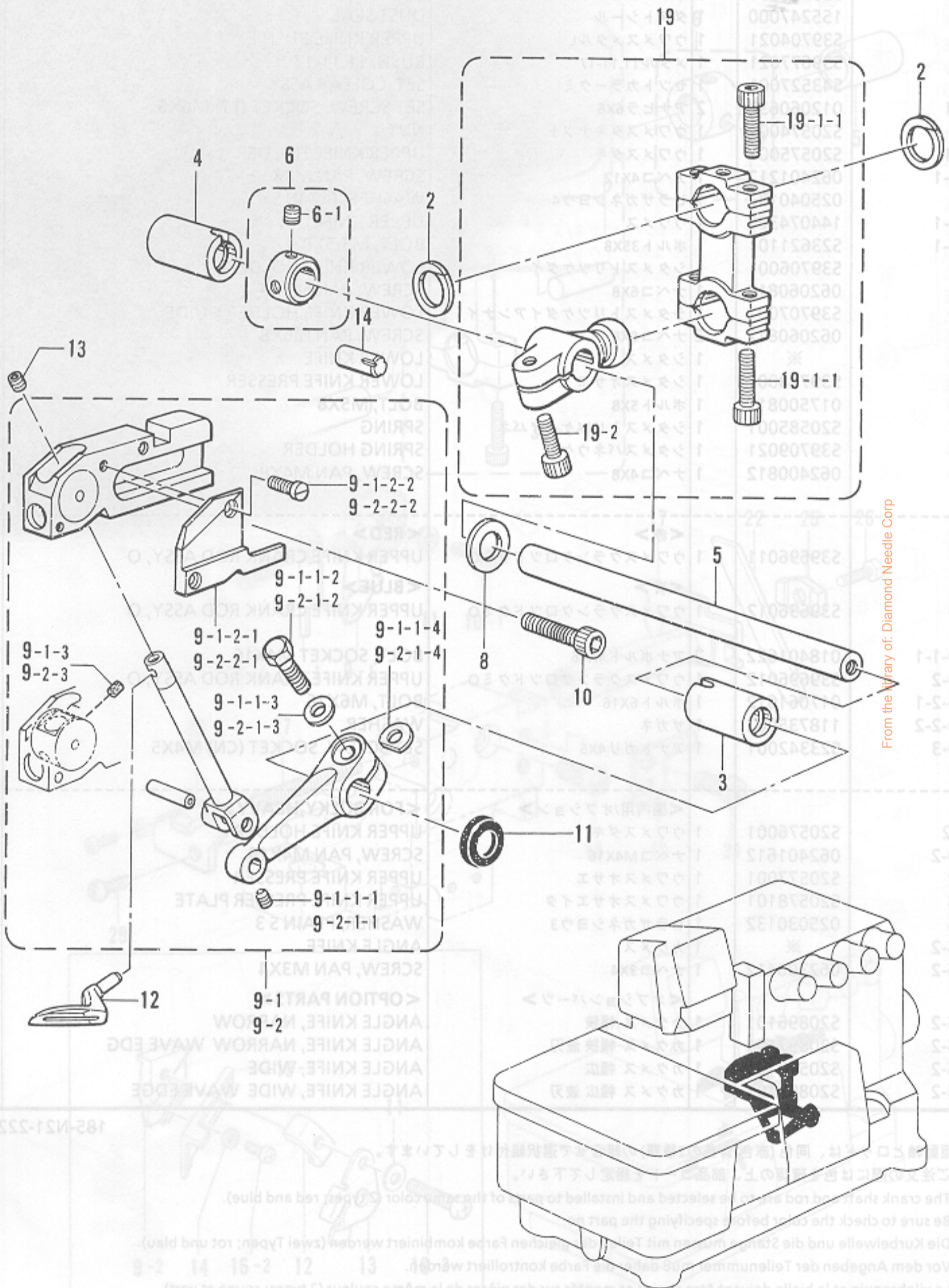

From the Library of: Diamond Needle Corp

185-N21-222

G. 上ルーパ関係 / Over looper mechanism / Oberen Greifer / Mécanisme du boucleur supérieur / Mecanismo del presilladora superior

REF.NO.	CODE	Q'TY	ヒンメイ	NAME OF PARTS	RM
2	S20598000	2	ロッドフレドメ	ROD STOPPER	
3	S39717021	1	ウワルーバジクメタルF	OVER LOOPER SHAFT BUSH, F	
4	S39677021	1	メタル11.11-17	BUSH, 11.11-17	
5	S39718021	1	ウワルーバジク	OVER LOOPER SHAFT	
6	S43527001	1	セットカラークミ	SET COLLAR ASSY	
6-1	012060632	2	アナヒラ6X6	SET SCREW, SOCKET (FT) M6X6	
10	018061432	2	アナホルト6X14	BOLT, SOCKET M6X14	
11	155247000	1	ダストシール	DUST SEAL	
12	S23※1101	1	ウワルーバル	OVER LOOPER	
13	012400432	1	アナヒラ4X4	SET SCREW, SOCKET (FT) M4X4	
14-1	118550001	1	ミゾツキピン	DOWEL PIN	
14-2	S40866001				
15	060351012				
19	S39715011	1	ウワルーバロツドクミHE <赤>	OVER LOOPER CONNECTING ROD <RED>	☆
19	S39715012	1	ウワルーバロツドクミHE <青>	OVER LOOPER CONNECTING ROD <BLUE>	☆
19-1-1	018401622	4	アナボルト4X16	BOLT, SOCKET M4X16	☆
19-2	018061432	1	アナホルト6X14	BOLT, SOCKET M6X14	☆
16-2	018061432				
8	S30562000	1	ザガネ <ハイリフト用>	WASHER <FOR HIGH-LIFT>	
9-1	S38313001	1	ウワルーバキコウクミSH	OVER LOOPER MECHANISM ASSY, SH	
9-1-1-1	S23342001	1	アナトガリ4X5	SET SCREW, SOCKET (CN) M4X5	
9-1-1-2	017061612	1	ボルト6X16	BOLT, M6X16	
9-1-1-3	118735002	1	ザガネ	WASHER	☆
9-1-1-4	155162001	1	スペーサ	SPACER	
9-1-2-1	S38320000	1	ウワルーバアンナイオサエ	OVER LOOPER GUIDE HOLDER	☆
9-1-2-2	S20355002	2	シメネジ3X8.5	SCREW, M3X8.5	
9-1-3	S29700000	2	ウワルーバアンナイフェルト	OVER LOOPER GUIDE FELT	
9-2	S38322001	1	ウワルーバキコウクミE <超ハイリフト用>	OVER LOOPER MECHANISM ASSY, E <FOR EXTRA HIGH-LIFT>	
9-2-1-1	S23342001	1	アナトガリ4X5	SET SCREW, SOCKET (CN) M4X5	
9-2-1-2	017061612	1	ボルト6X16	BOLT, M6X16	
9-2-1-3	118735002	1	ザガネ	WASHER	
9-2-1-4	155162001	1	スペーサ	SPACER	
9-2-2-1	S38320000	1	ウワルーバアンナイオサエ	OVER LOOPER GUIDE HOLDER	
9-2-2-2	S20355002	2	シメネジ3X8.5	SCREW, M3X8.5	
9-2-3	S29700000	2	ウワルーバアンナイフェルト	OVER LOOPER GUIDE FELT	

From the library of: Diamond Needle Corp

185-N21-307

☆ 駆動軸とロッドは、同色 (赤色・青色の2種類) の組合せで選択組付けをしています。

ご注文の際には色を確認の上、部品コードを指定して下さい。

☆ The crank shaft and rod are to be selected and installed to parts of the same color (2 types; red and blue).

Be sure to check the color before specifying the part no.

☆ Die Kurbelwelle und die Stange müssen mit Teilen der gleichen Farbe kombiniert werden (zwei Typen; rot und blau).

Vor dem Angeben der Teilenummer muß daher die Farbe kontrolliert werden.

☆ Le vilebrequin et la bielle doivent être choisis et montés sur des pièces de la même couleur (2 types; rouge et vert).

Veiller à bien vérifier la couleur avant d'indiquer le code numéroté de pièce.

☆ El cigüeñal y la varilla se deben seleccionar e instalar con las piezas del mismo color (dos tipos; rojas y azules).

Antes de especificar el código de pieza se debe verificar el color.

H. 下ルーパ関係 / Under looper mechanism / Unterer Greifer  
 / Mécanisme du boucleur inférieur / Mecanismo del presilladora inferior

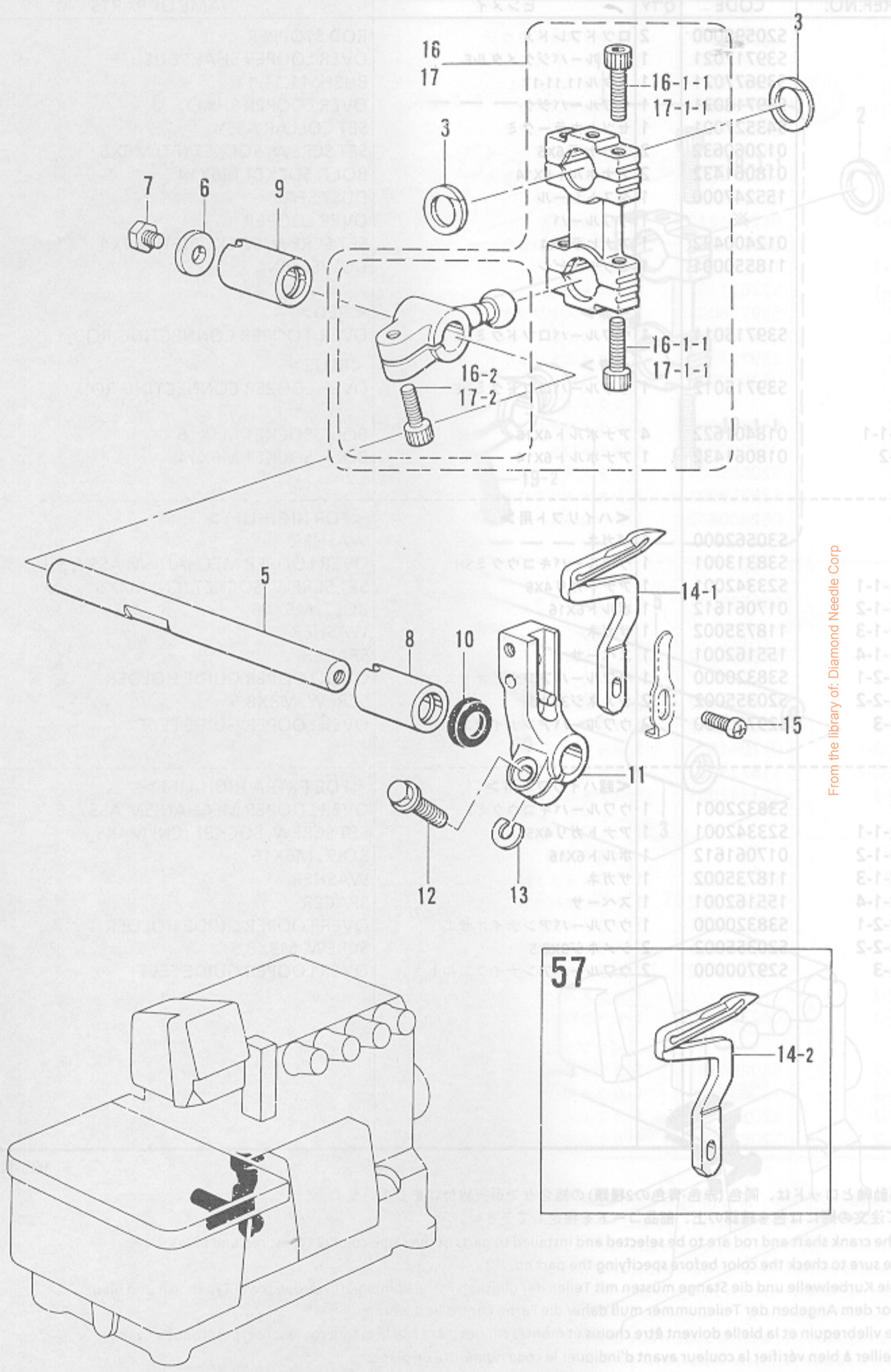

From the library of: Diamond Needle Corp

H. 下ルーパ関係 / Under looper mechanism / Unterer Greifer  
/ Mécanisme du boucleur inférieur / Mecanismo del presilladora inferior

REF.NO.	CODE	Q'TY	ヒンメイ	NAME OF PARTS	RM
3	S20598000	2	ロッドフレドメ	ROD STOPPER	
5	S20622001	1	シタルーバジク	UNDER LOOPER SHAFT	
6	S23626001	1	ザガネ	WASHER	
7	017060812	1	ボルト6X8	BOLT, M6X8	
8	S39728021	1	シタルーバジクメタルF	UNDER LOOPER SHAFT BUSH, F	
9	S39677021	1	メタル11.11-17	BUSH, 11.11-17	
10	155247000	1	ダストシール	DUST SEAL	
11	S20625001	1	シタルーバトリツケダイ	UNDER LOOPER HOLDER	
12	S23614101	1	フランジボルト5X14	BOLT, M5X14	
13	148782001	1	スペーサ	SPACER	
14-1	S20627001	1	シタルーバ	UNDER LOOPER	
14-2	S40866001	1	シタルーバ	UNDER LOOPER	
15	060351012	1	バインド3.5X10	SCREW, BIND M3.5X10	
<hr/>					
"ハイリフト用"				FOR "HIGH-LIFT"	
<赤>				<RED>	
16	S39720011	1	シタルーバロッドクミOSH	UNDER LOOPER CONNECTING ROD	☆
<青>				<BLUE>	
16	S39720012	1	シタルーバロッドクミOSH	UNDER LOOPER CONNECTING ROD	☆
16-1-1	018401622	4	アナボルト4X16	BOLT, SOCKET M4X16	
16-2	018061432	1	アナボルト6X14	BOLT, SOCKET M6X14	
<hr/>					
"超ハイリフト用"				FOR "EXTRA HIGH-LIFT"	
<赤>				<RED>	
17	S39722011	1	シタルーバロッドクミOE	UNDER LOOPER CONNECTING ROD	☆
<青>				<BLUE>	
17	S39722012	1	シタルーバロッドクミOE	UNDER LOOPER CONNECTING ROD	☆
17-1-1	018401622	4	アナボルト4X16	BOLT, SOCKET M4X16	
17-2	018061432	1	アナボルト6X14	BOLT, SOCKET M6X14	
21	S20571000	1	クミヒモ100	WICK (L=100)	
22	S20571000	1	クミヒモ100	WICK (L=100)	
23	S20669990	1	フェルト	FELT	
24	060400812	1	バインドM4X8	SCREW, BIND M4X8	
29	S43523000	1	フィルタークミ	OIL FILTER ASSY	
29-1	S43521000	1	ロカモウD	OIL FILTER, D	
29-2	S43522000	1	オイルフィルター	OIL FILTER	

From the library of: Diamond Needle Corp

185-N21-308

☆ 駆動軸とロッドは、同色(赤色・青色の2種類)の組合せで選択組付けをしています。

ご注文の際には色を確認の上、部品コードを指定して下さい。

☆ The crank shaft and rod are to be selected and installed to parts of the same color (2 types; red and blue).  
Be sure to check the color before specifying the part no.

☆ Die Kurbelwelle und die Stange müssen mit Teilen der gleichen Farbe kombiniert werden (zwei Typen; rot und blau).  
Vor dem Angeben der Teilenummer muß daher die Farbe kontrolliert werden.

☆ Le vilebrequin et la bielle doivent être choisis et montés sur des pièces de la même couleur (2 types; rouge et vert).  
Veiller à bien vérifier la couleur avant d'indiquer le code numéroté de pièce.

☆ El cigüeñal y la varilla se deben seleccionar e instalar con las piezas del mismo color (dos tipos; rojas y azules).  
Antes de especificar el código de pieza se debe verificar el color.

185-N21-350

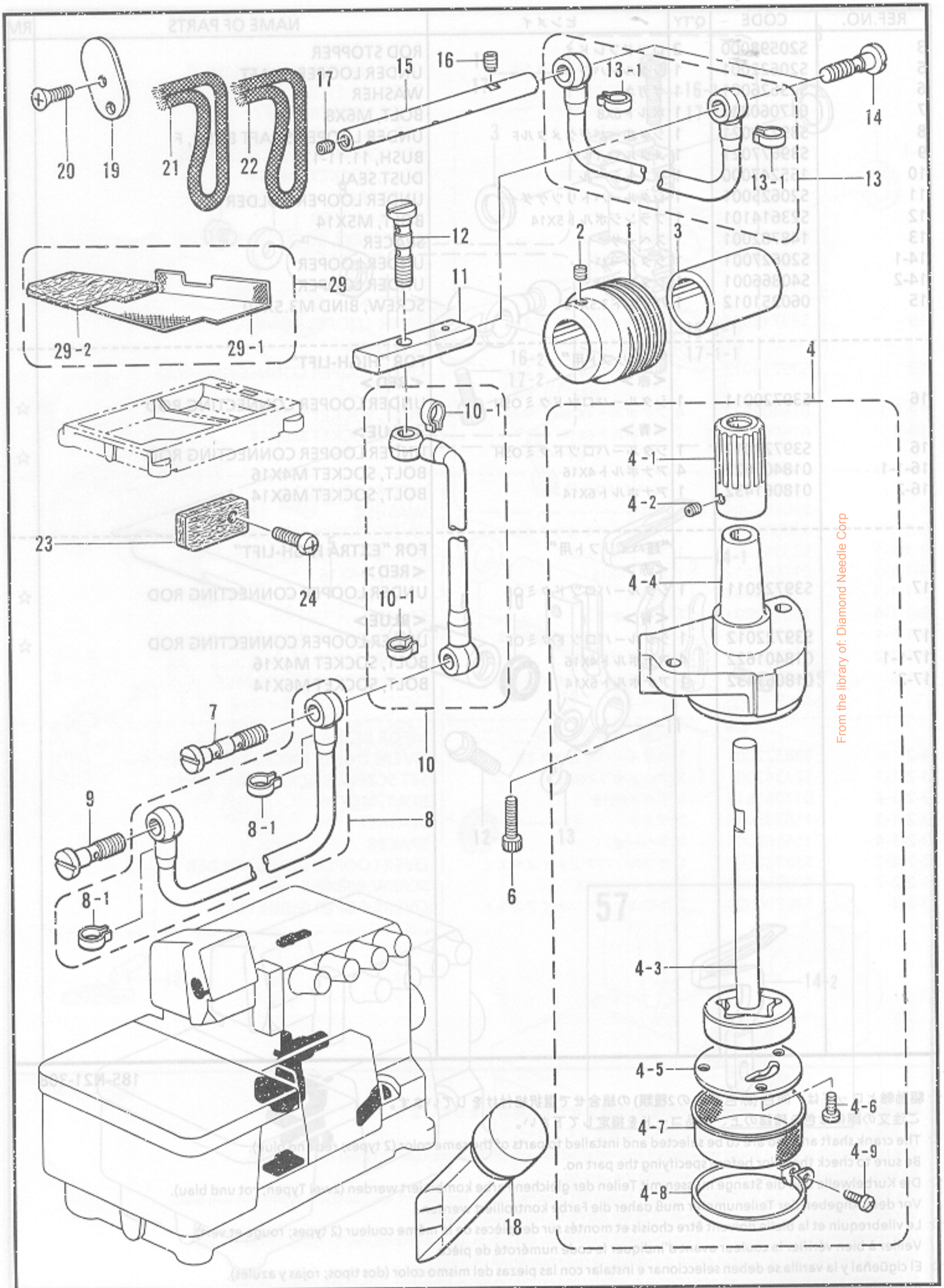

From the library of: Diamond Needle Corp

REF.NO.	CODE	Q'TY	ヒンメイ	NAME OF PARTS	RM
1	S20655101	1	ウオーム	WORM	
2	012500532	2	アナヒラ5X5	SET SCREW, SOCKET (FT) M5X5	
3	S39743001	1	カラー	COLLAR	
4	S39597001	1	トロコイドポンプクミ	PUMP ASSY	
4-1	S20657001	1	ウオームホイール	WORM WHEEL	
4-2	012400432	2	アナヒラ4X4	SET SCREW, SOCKET (FT) M4X4	
4-3	S39599001	1	ポンプロータークミ	PUMP INNER ROTER ASSY	
4-4	S39598000	1	ポンプケース	PUMP CASE	
4-5	S39601000	1	ポンプタイフタ	PUMP BODY COVER	
4-6	062400812	3	ナベコ4X8	SCREW, PAN M4X8	
4-7	S39602000	1	ロカモウ	OIL FILTER	
4-8	S39603001	1	ロカモウオサエ	OIL FILTER FLANGE	
4-9	062401212	1	ナベコ4X12	SCREW, PAN M4X12	
6	018061432	2	アナホルト6X14	BOLT, SOCKET M6X14	
7	S39744021	1	ハイユパイプツギテ	OIL PIPE JOINT	
8	S39745001	1	ビニルチューブクミ	OIL TUBE ASSY	
8-1	147942001	2	ビニルチューブトメガネ	STOP RING	
9	S20199001	1	ハイコパイプツギテ	OIL PIPE JOINT	
10	S39747001	1	ビニルチューブクミ	OIL TUBE ASSY	
10-1	147942001	2	ビニルチューブトメガネ	STOP RING	
11	S39751021	1	キユウユパイプ	OIL PIPE	
12	S39744021	1	ハイユパイプツギテ	OIL PIPE JOINT	
13	S39749001	1	ビニルチューブクミ	OIL PIPE ASSY	
13-1	147942001	2	ビニルチューブトメガネ	STOP RING	
14	S20199001	2	ハイコパイプツギテ	OIL PIPE JOINT	
15	S39752021	1	ロツドキユウユパイプ	OIL PIPE	
16	012400432	1	アナヒラ4X4	SET SCREW, SOCKET (FT) M4X4	
17	012060632	1	アナヒラ6X6	SET SCREW, SOCKET (FT) M6X6	
18	148084001	1	オイルゲージマド	OIL GAUGE WINDOW	
19	S20668000	1	ハリボウリンクフェルト	NEEDLE BAR LINK FELT	
20	061400812	1	サラコM4X8	SCREW, FLAT M4X8	
21	S20671000	1	クミヒモ100	WICK (L = 100)	
22	S20671000	1	クミヒモ100	WICK (L = 100)	
23	S20669000	1	フェルト	FELT	
24	060400812	1	バインドM4X8	SCREW, BIND M4X8	
29	S43523000	1	フィルタークミ	OIL FILTER ASSY	
29-1	S43521000	1	ロカモウD	OIL FILTER, D	
29-2	S43522000	1	オイルフィルター	OIL FILTER	
49	S20690001	1	バインドオサエバネ	SPRING	
50	S20691001	1	バインドオサエイタ	NEEDLE THREAD PRESSER PLATE	
51	S20692001	1	ハリボウリンク	NEEDLE THREAD GUIDE	
52	060300512	1	バインドM3X5	SCREW, BIND M3X5	

From the library of: Diamond Needle Corp

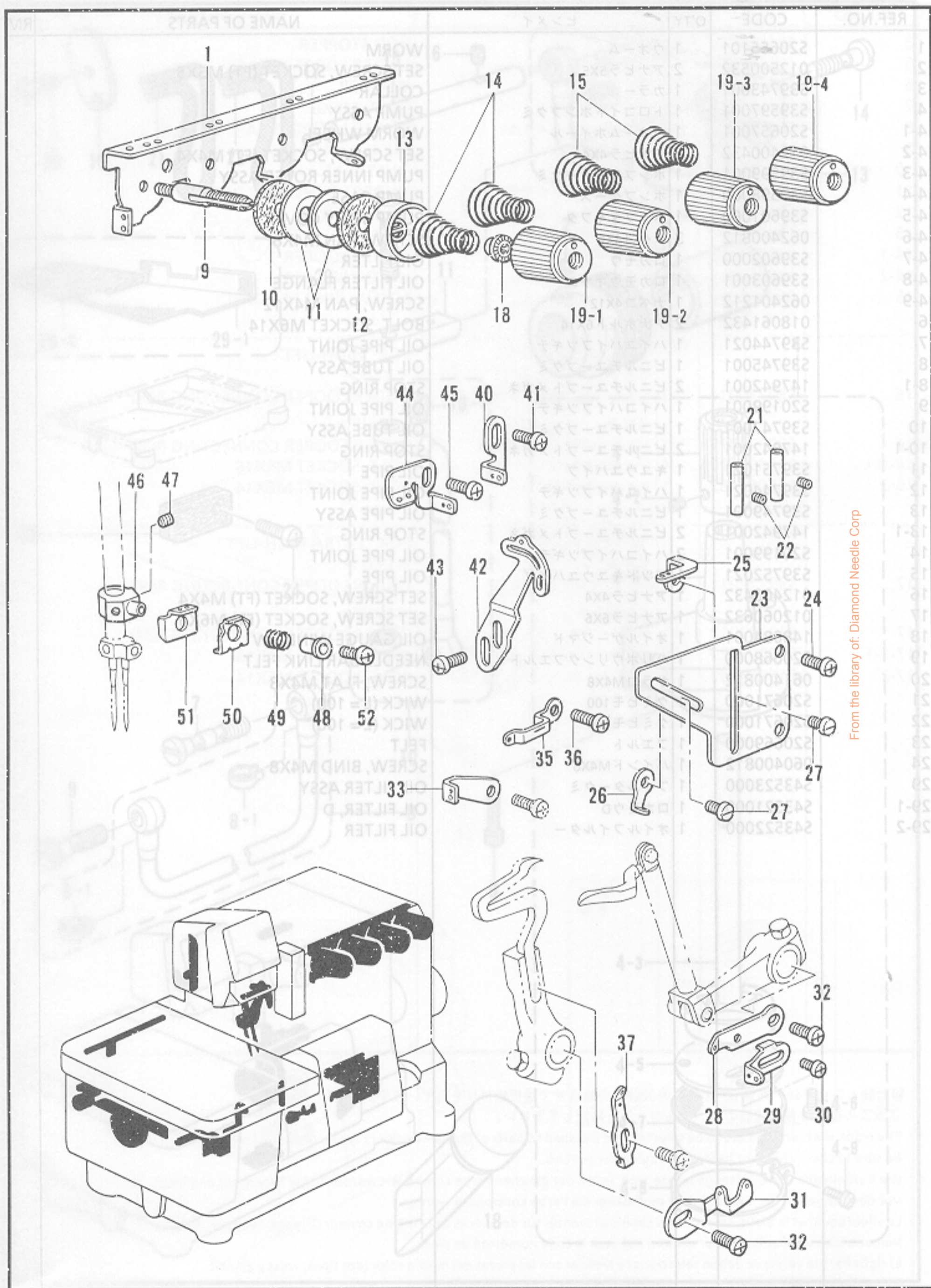

From the library of: Diamond Needle Corp

K. 糸調子関係 / Thread tension / Faderspannung / Tension du fil / Tensión del hilo

REF.NO.	CODE	Q'TY	ヒンメイ	NAME OF PARTS	RM
1	S38328051	1	シュイトアンナイ	MAIN THREAD GUIDE	
9-1	S20676001	4	イトチヨウシボウ	TENSION STUD	
10	S20677000	4	イトチヨウシサラフェルト	TENSION DISC FELT	
11	S20673001	8	イトチヨウシサラ	TENSION DISC	
12	110832009	4	イトチヨウシサラフェルト	TENSION DISC FELT	
13	144103009	4	イトチヨウシサラオサエ	TENSION DISC PRESSER	
14	S20678001	2	イトチヨウシバネL	TENSION SPRING, L	
15	S20679001	2	イトチヨウシバネM	TENSION SPRING, M	
18	S20681000	4	チヨウシバネウエザガネ	WASHER	
19-1	S20682103	1	イトチヨウシナツト 赤	TENSION NUT, RED	
19-2	S20682101	1	イトチヨウシナツト 水色	TENSION NUT, LIGHT BLUE	
19-3	S20682104	1	イトチヨウシナツト 黄色	TENSION NUT, YELLOW	
19-4	S20682102	1	イトチヨウシナツト 緑	TENSION NUT, GREEN	
21	146592001	2	イトアンナイパイプ	THREAD GUIDE PIPE	
22	S23452002	2	アナヒラ4X3.2	SET SCREW, SOCKET (FT) M4X3.2	
23	S20684101	1	イトアンナイドダイ	THREAD GUIDE BRACKET	
24	060400612	2	バインドM4X6	SCREW, BIND M4X6	
25	S20685001	1	シタルーバイトアンナイR	UNDER LOOPER THREAD GUIDE, R	
26	S20686001	1	ウフルーバイトアンナイR	OVER LOOPER THREAD GUIDE, R	
27	S23418002	2	シメネジ4X5	SCREW, M4X5	
28	S21133001	1	ウフルーバテンビンR	OVER LOOPER THREAD TAKE-UP, R	
29	S21134001	1	シタルーバテンビンR	UNDER LOOPER THREAD TAKE-UP, R	
30	060300412	1	バインドM3X4	SCREW, BIND M3X4	
31	S21135001	1	ルーバテンビンL	LOOPER THREAD TAKE-UP, L	
32	060400612	2	バインドM4X6	SCREW, BIND M4X6	
33	S21137001	1	ルーバイトアンナイM1	LOOPER THREAD GUIDE, M1	
35	S21136101	1	ウフルーバイトアンナイL	OVER LOOPER THREAD GUIDE, L	
36	060400612	1	バインドM4X6	SCREW, BIND M4X6	
37	S20687001	1	シタルーバイトアンナイL	UNDER LOOPER THREAD GUIDE, L	
40	S21129001	1	ハリイトアンナイB	NEEDLE THREAD GUIDE, B	
41	060400612	1	バインドM4X6	SCREW, BIND M4X6	
42	S21130001	1	ハリイトテンビンA	NEEDLE THREAD TAKE-UP, A	
43	060400612	2	バインドM4X6	SCREW, BIND M4X6	
44	S21128001	1	ハリイトアンナイA	NEEDLE THREAD GUIDE, A	
45	060400612	1	バインドM4X6	SCREW, BIND M4X6	
46	S38330050	1	ハリイトオサエホルダー	NEEDLE THREAD PRESSER HOLDER	
47	146427001	2	アサトメネジ3.18クボミ	SET SCREW, SOCKET (CP) SM3.18	
48	S20689001	1	ハリイトオサエカラー	NEEDLE THREAD PRESSER COLLAR	
49	S20690001	1	ハリイトオサエバネ	SPRING	
50	S20691001	1	ハリイトオサエイタ	NEEDLE THREAD PRESSER PLATE	
51	S20692001	1	ハリイトアンナイ	NEEDLE THREAD GUIDE	
52	060300512	1	バインドM3X5	SCREW, BIND M3X5	

From the library of: Diamond Needle Corp



L. 針冷却装置 / Needle cooler / Nadelkühlungsvorrichtung  
 / Mécanisme du refroidisseur d'aiguille / Mecanismo del enfriador de aguja

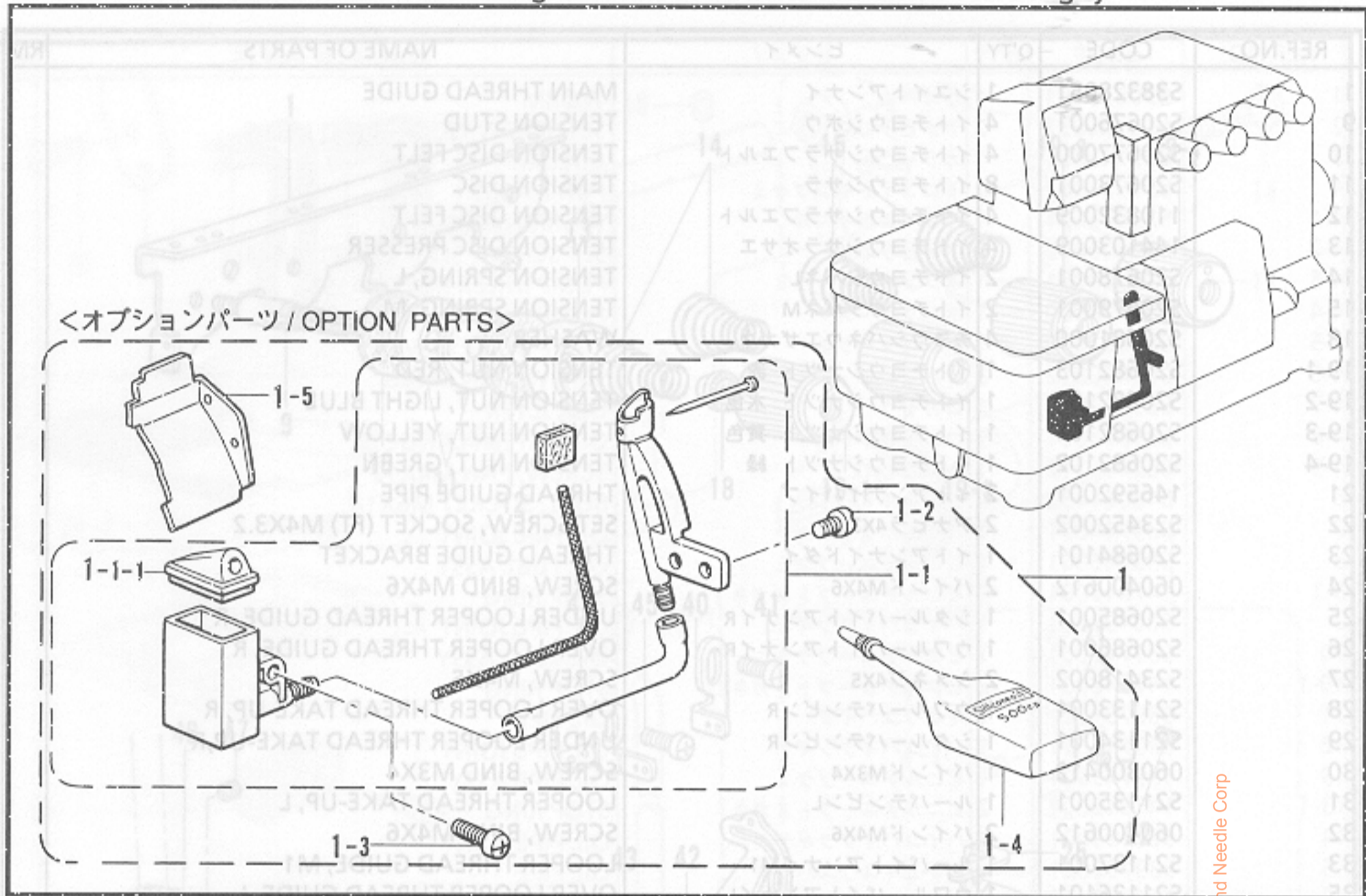

185-N21-124

M. ヒモ案内関係 / Gimp guide mechanism / Schnurführung / Mécanisme de guide-fil  
 / Mecanismo guía del hilo

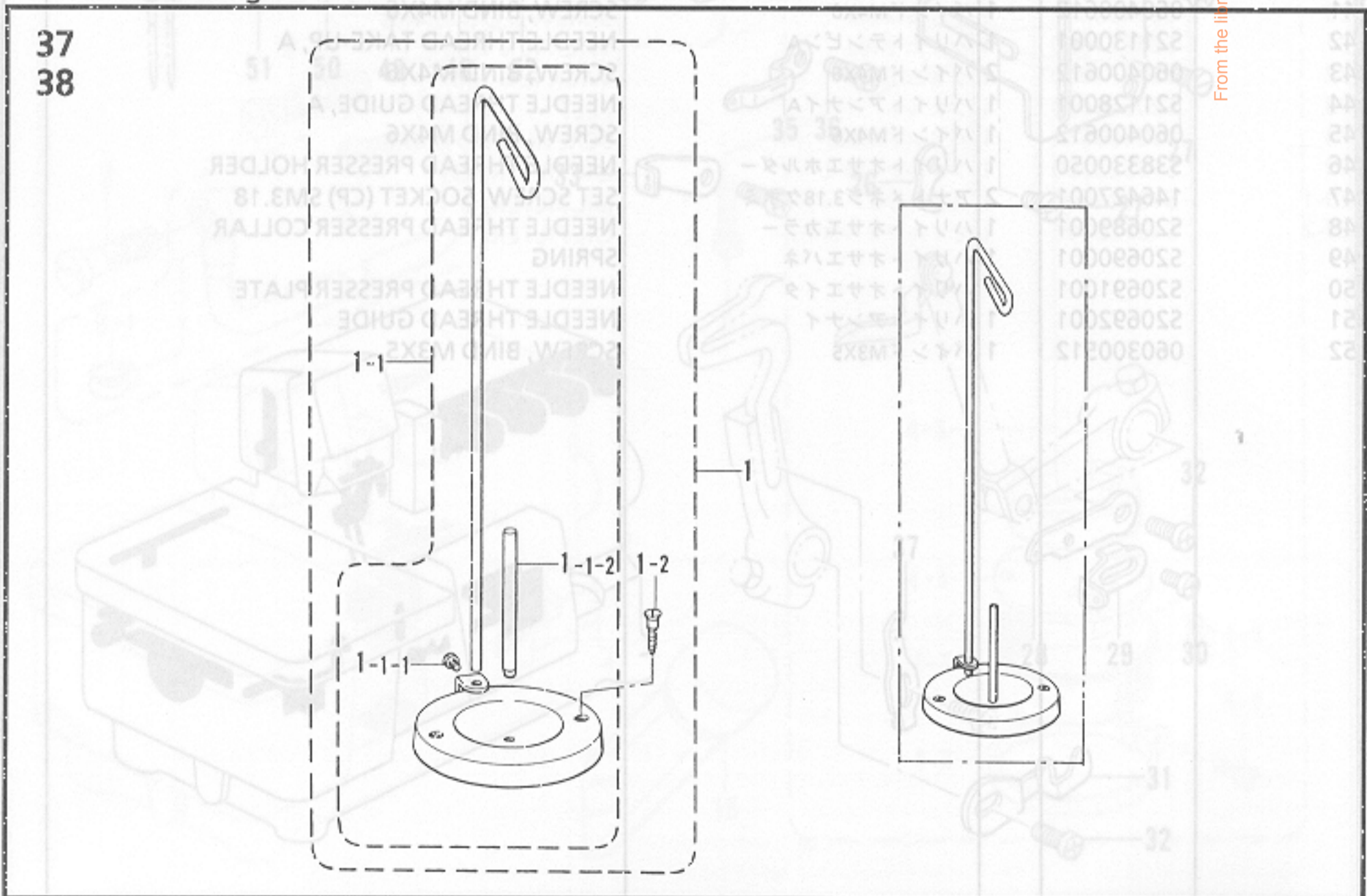

From the library of: Diamond Needle Corp

L. 針冷却装置 / Needle cooler / Nadelkühlungsvorrichtung  
 / Mécanisme du refroidisseur d'aiguille / Mecanismo del enfriador de aguja

REF.NO.	CODE	Q'TY	ヒンメイ	NAME OF PARTS	RM
1	143767002 S43524001	1	<オプション用> ハリレイキヤクセットO	<FOR OPTION> NEEDLE COOLER SET, O	
1-1	S20453001	1	フェルトササエクミ	FELT SUPPORT ASSY	
1-1-1	S20460000	1	シリコンタンクフタ	SILICONE TANK CAP	
1-2	S23418002	2	シメネジ4X5 ナット	SCREW, M4X5	
1-3	060401012	1	バインドM4X10	SCREW, BIND M4X10	
1-4	S06704001	1	シリコンオイル	SILICONE OIL	
1-5	S20322101	1	マエカバーS	FRONT COVER, S	

From the library of: Diamond Needle Corp

M. ヒモ案内関係 / Gimp guide mechanism / Schnurführung / Mécanisme de guide-fil  
 / Mecanismo guía del hilo

REF.NO.	CODE	Q'TY	ヒンメイ	NAME OF PARTS	RM
1	S20130009	1	イトタテダイクミネジツキ	COTTON STAND WITH SCREW	
1-1	S20131009	1	イトタテダイクミ	COTTON STAND ASSY	
1-1-1	S20134001	1	シメネジW4.76-24X10	SCREW, W4.76-24X10	
1-1-1	S20135001	1	イトタテボウ	SPOOL PIN	
1-2	034422006	2	+2サラモク41X20	WOOD SCREW, FLAT 2 M4.1X20	

From the library of: Diamond Needle Corp

N. テープワインダー関係 / Tape winder mechanism / Bandaufwickelvorrichtung  
 / Mécanisme de l'enrouleur de ruban / Mecanismo bobinador de cinta

37  
38

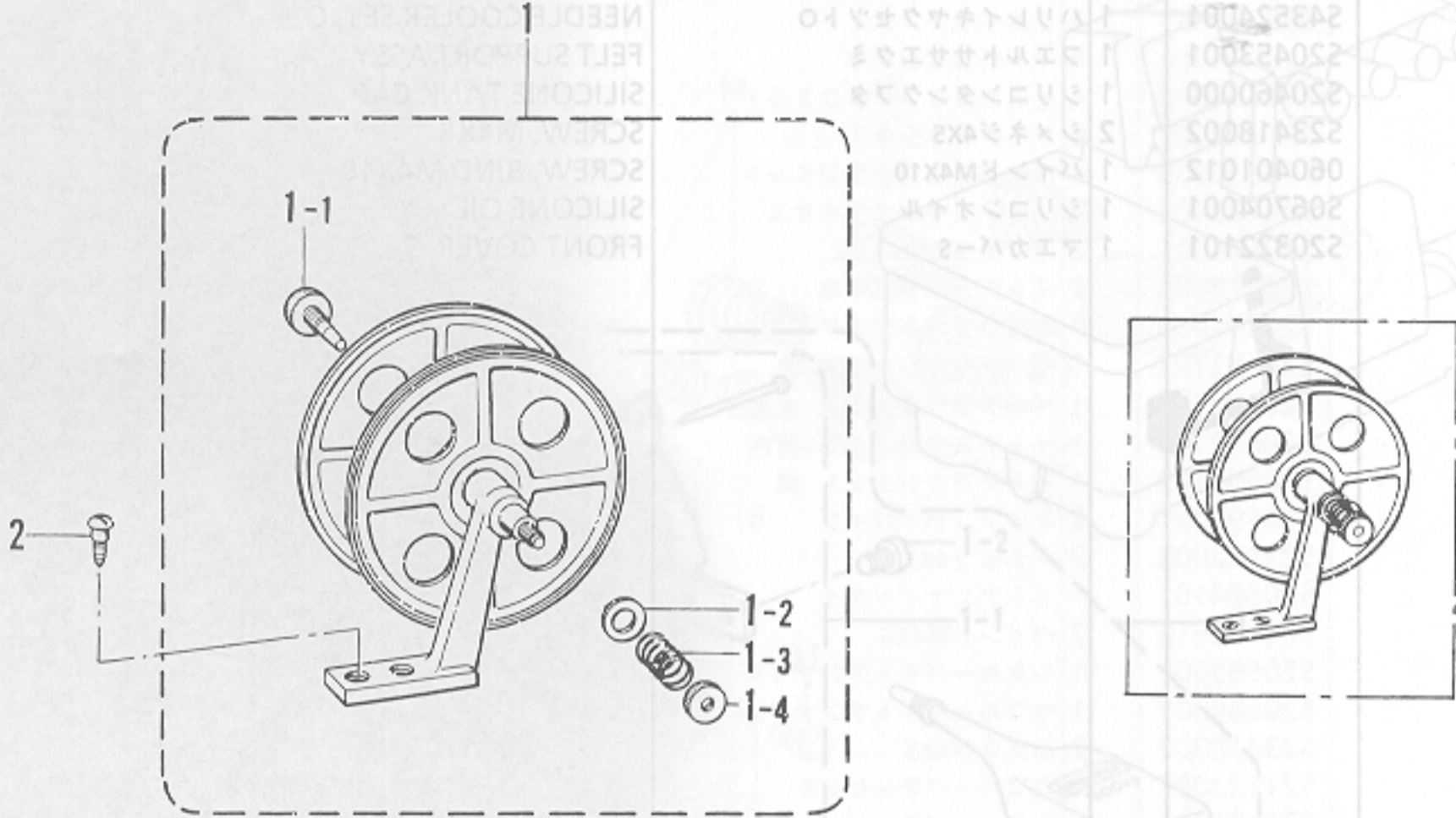

185-N21-221

P. ラッパー関係 / Lapper mechanism / Falz-mechanismus / Mécanisme à rabat  
 / Mecanismo de solapado

37  
38

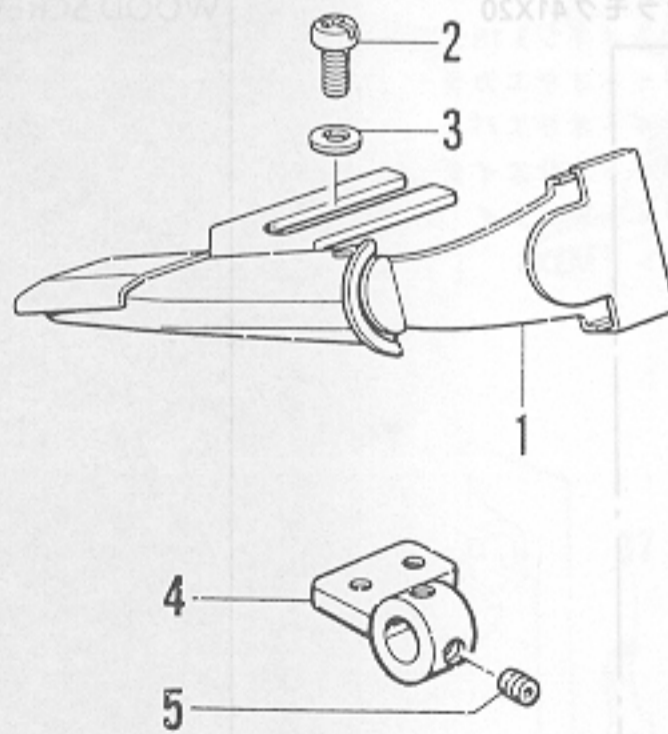

185-N21-239

N. テープワインダー関係 / Tape winder mechanism / Bandaufwickelvorrichtung  
 / Mécanisme de l'enrouleur de ruban / Mecanismo bobinador de cinta

REF.NO.	CODE	Q'TY	ヒンメイ	NAME OF PARTS	RM
1	143767002	1	テープワインダークミ	TAPE WINDER ASSY	
1-1	143980001	1	ツマミネジ	SCREW	
1-2	108494001	1	ザガネ	WASHER	
1-3	108495001	1	テープワインダオシバネ	SPRING	
1-4	100136001	1	イトチヨウシナツト	TENSION NUT	
2	101118001	2	マルモクネジ4.5X20	WOOD SCREW, ROUND M4.5X20	
1-4	S23321001		アタマツキトメネジ6	SET SCREW, M6	
1-5	B20671001		イトチヨウシボウ	TENSION STUD	
1-7	S23775001		コイルバネ	COIL SPRING	
1-8	S28681001		チヨウシバネウエザガネ	WASHER	
1-9	S20682101		イトチヨウシナツト	TENSION NUT	
1-10	S25005001		キジオサエ	RUFFLING BLADE	
1-11	144784001		キジオサエザガネ	WASHER	
1-12	062370812		ナベコ4X8	SCREW, PAN M3X8	
1-13	S21293001		ナベコ	RUFFLER BASE	
1-14	S21318001		ダンネジ6	STUD SCREW 6	
1-15	S21387001		バネ	WASHER, SPRING	
1-16	S21298001		ナベコ6X6	RUFFLING BLADE GUIDE	
1-17	062370812		ナベコ3.5X8	SCREW, PAN M3.5X8	
1-18	S39295001		キジオサエアゲ	CLOTH PRESSER BAR LIFTER	
1-19	S23651002		アナヒラ6X6ホソメ	SET SCREW, SOCKET (FT) M6X5	
1-20	S21306001		ハンドルトリツゲイタ	HANDLE SET PLATE	
1-21	027060302		ナツト3M	NUT, 3 M	
1-22	062401612		ナベコM4X16	SCREW, PAN M4X16	
1-23	021400212		2シユナツト4	NUT, 2 M4	
1-24	S21301001		ハンドルモト	SPRING	
1-25	S21302001		キジオサエタイメ	SPRING PLATE (U)	
1-26	062350612		ナベコM3.5X6	SCREW, PAN M3.5X6	
1-27	S21303001		コイルバネ	SPRING	
1-28	S21304001		ナベコM3.5X8	SCREW, PAN M3.5X8	
1-29	S21305001		ナベコM3.5X8	SCREW, PAN M3.5X8	

185-N21-221

P. ラッパー関係 / Lapper mechanism / Falz-mechanismus / Mécanisme à rabat  
 / Mecanismo de solapado

REF.NO.	CODE	Q'TY	ヒンメイ	NAME OF PARTS	RM
1	S21318000	1	ラツパークミ	LAPPER ASSY	
2	062400812	2	ナベコ4X8	SCREW, PAN M4X8	
3	025040232	2	ヒラザガネチユウ4	WASHER, PLAIN M 4	
4	S25019001	1	ラツパードダイ	LAPPER BASE	
5	S23651002	2	アナヒラ6X6ホソメ	SET SCREW, SOCKET (FT) M6X5	
8	S43530001		ラフラー	RUFFLER INTERLOCKING PARTS SET	
8	S21310001		キジオサエアゲ	CLOTH PRESSER BAR LIFTER LEVER	
9	S21311001		オシバネ	PRESSER BAR LIFTER BRACKET	
10	S21312001		ピン6.35	PIN 6.35	
11	012060632		アナヒラ6X6	SET SCREW, SOCKET (FT) M6X6	
12	062350812		ナベコM3.5X8	SCREW, PAN M3.5X8	
13	S39795001		ワイヤ	WIRE SET PLATE	
14	S21314001		フレキシブルワイヤ	FLEXIBLE WIRE ASSY	
15	S23774001		タメネ	SHOULDER SCREW, M3.5	
16	S21315001		ナベコM4	STUD M4	
17	021400212		2シユナツト4	NUT, 2 M4	
18	S21316001		ワイヤーストッパー	WIRE STOPPER	
19	062400432		アナヒラ4X4	SET SCREW, SOCKET (FT) M4X4	
29	S39796008		スペーサ	SPACER	

185-N21-239

Q. ラフラー装置 / Ruffling attachment / Kräuselvorrichtung / Accessoire pour fronces  
 / Accesorio de fruncido

33  
 34  
 37  
 38

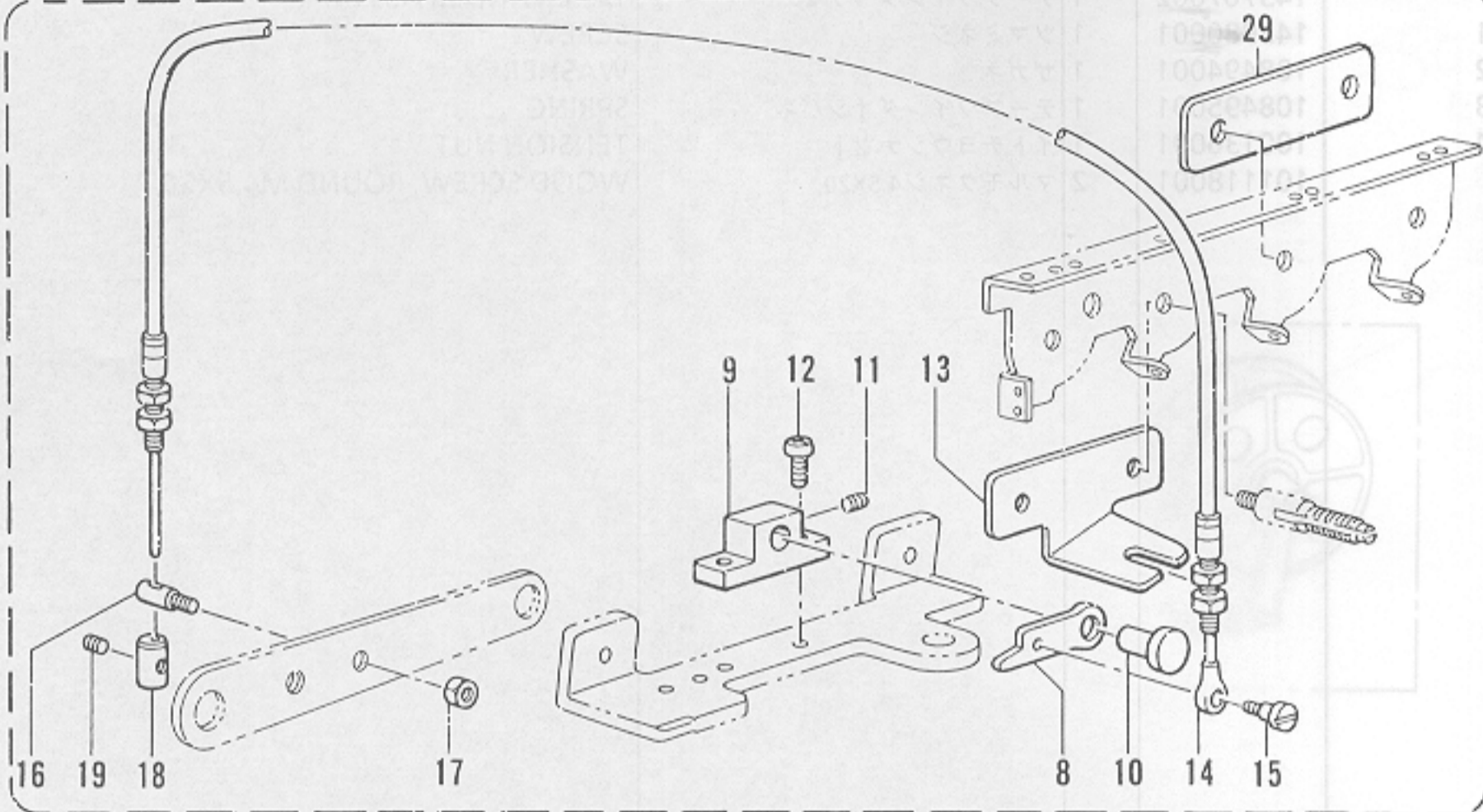

B

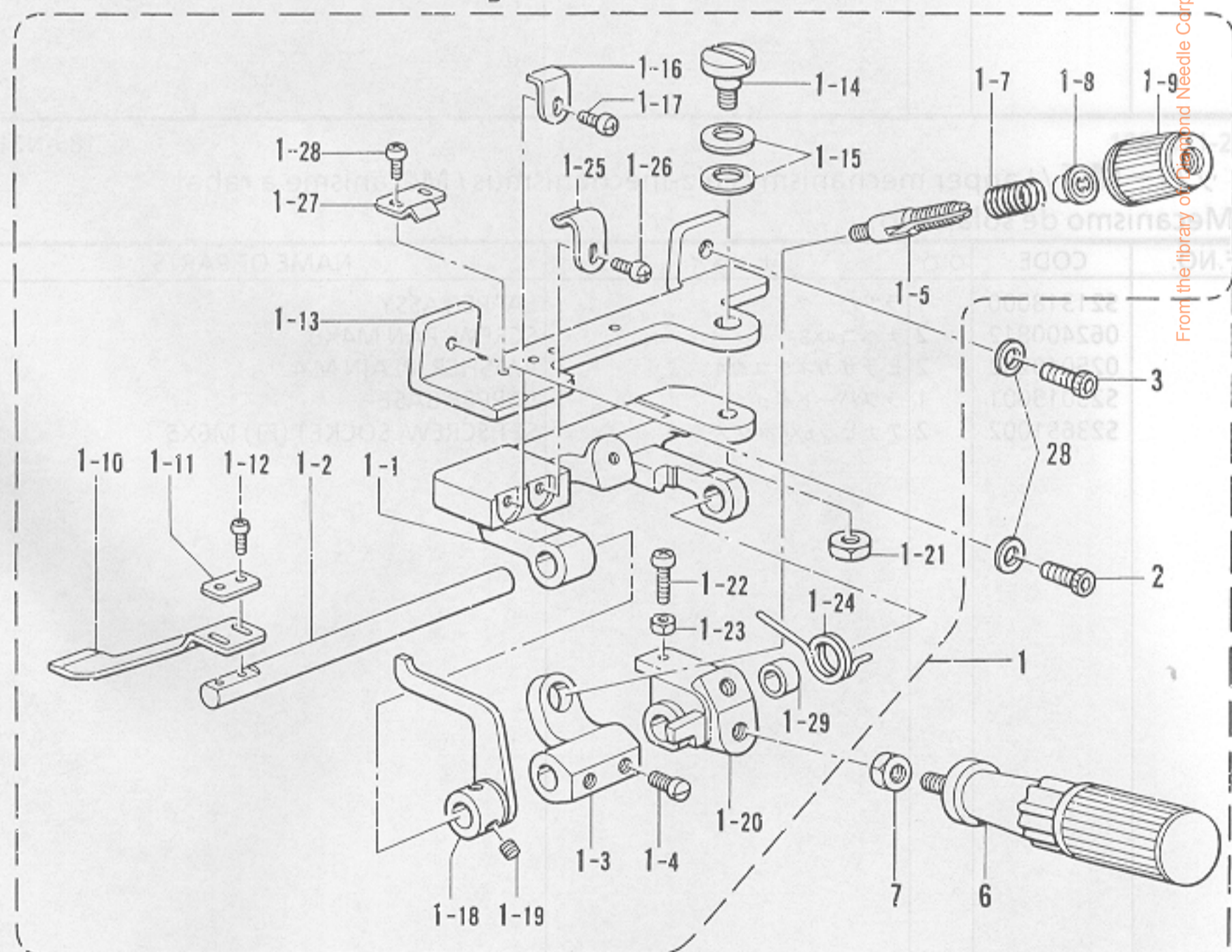

A

From the library of [www.needlenet.com](http://www.needlenet.com)

Q. ラフラー装置 / Ruffling attachment / Kräuselvorrichtung / Accessoire pour fronces  
/ Accesorio de fruncido

REF.NO.	CODE	Q'TY	ヒンメイ	NAME OF PARTS	RM
A	S30134001	1	ラフラークミ	RUFFLER ASSY	
1	S25006001	1	ラフラーソウチクミ	RUFFLER ATTACHMENT ASSY	
1-1	S21294001	1	キジオサエタイ	RUFFLING BLADE BRACKET	
1-2	S21295001	1	キジオサエトリツケジク	RUFFLING BLADE BASE SHAFT	
1-3	S21305001	1	バネウケ	SPRING BASE	
1-4	S23777101	2	アタマツキトメネジ6	SET SCREW, M6	
1-5	S20676001	1	イトチヨウシボウ	TENSION STUD	
1-7	S23775001	1	コイルバネ	COIL SPRING	
1-8	S20681000	1	チヨウシバネウエザガネ	WASHER	
1-9	S20682105	1	イトチヨウシナツト	TENSION NUT	
1-10	S25005001	1	キジオサエ	RUFFLING BLADE	
1-11	144784001	1	キジオサエザガネ	WASHER	
1-12	062300812	2	ナベコ3X8	SCREW, PAN M3X8	
1-13	S21297001	1	ラフラーソウチトリツケダイ	RUFFLER BASE	
1-14	S21306001	1	ダンネジ6	STUD SCREW 6	
1-15	S21307001	2	バネザガネ	WASHER, SPRING	
1-16	S21298001	1	キジオサエアンナイ	RUFFLING BLADE GUIDE	
1-17	062350812	1	ナベコ3.5X8	SCREW, PAN M3.5X8	
1-18	S21299001	1	キジオサエアゲ	CLOTH PRESSER BAR LIFTER	
1-19	S23651002	2	アナヒラ6X6ホソメ	SET SCREW, SOCKET (FT) M6X5	
1-20	S21300001	1	ハンドルトリツケイタ	HANDLE SET PLATE	
1-21	021060302	1	ナツト3シユ6	NUT, 3 M6	
1-22	062401612	1	ナベコM4X16	SCREW, PAN M4X16	
1-23	021400212	1	2シユナツト4	NUT, 2 M4	
1-24	S21301001	1	ハンドルモドシバネ	SPRING	
1-25	S21302001	1	キジオサエタイトメバネU	SPRING PLATE (U)	
1-26	062350612	1	ナベコM3.5X6	SCREW, PAN M3.5X6	
1-27	S21303001	1	キジオサエタイトメバネD	SPRING PLATE (D)	
1-28	062350512	2	ナベコ3.5X5	SCREW, PAN M3.5X5	
1-29	S21304001	1	カラー	COLLAR	
2	018401632	1	アナボルトM4X16	BOLT M4X16	
3	018401032	1	アナボルト4X10	BOLT 4X10	
4	S21590000	1	キジオアンナイ	RUFFLER GUIDE	
5	S23418002	2	シメネジ4X5	SCREW, M4X5	
6	S23779001	1	ハンドル	HANDLE	
7	021060302	1	ナツト3シユ6	NUT, 3 M6	
28	102707002	2	ザガネ	WASHER, PLAIN 4	
B	S43530001	1	ラフラーオサエレンドウクミ	RUFFLER INTERLOCKING PARTS SET	
8	S21310001	1	キジオサエアゲ	CLOTH PRESSER BAR LIFTER LEVER	
9	S21311001	1	オサエアゲダイ	PRESSER BAR LIFTER BRACKET	
10	S21312001	1	ピン6.35	PIN 6.35	
11	012060632	1	アナヒラ6X6	SET SCREW, SOCKET (FT) M6X6	
12	062350812	2	ナベコ3.5X8	SCREW, PAN M3.5X8	
13	S39795001	1	ワイヤートリツケイタ	WIRE SET PLATE	
14	S21314001	1	フレキシブルワイヤークミ	FLEXIBLE WIRE ASSY	
15	S23774001	1	ダンネジ3.5	SHOULDER SCREW, M3.5	
16	S21315001	1	スタツドM4	STUD M4	
17	021400212	1	2シユナツト4	NUT, 2 M4	
18	S21316001	1	ワイヤーストツパー	WIRE STOPPER	
19	012400432	1	アナヒラ4X4	SET SCREW, SOCKET (FT) M4X4	
29	S39796001	1	スペーサ	SPACER	

From the library of: Diamond Needle Corp

Q. ラフラー装置 / Ruffling attachment / Kräuselvorrichtung / Accessoire pour fronces  
/ Accesorio de fruncido

33 半沈用 / FOR SEMI-SUBMERGED

34  
37  
38

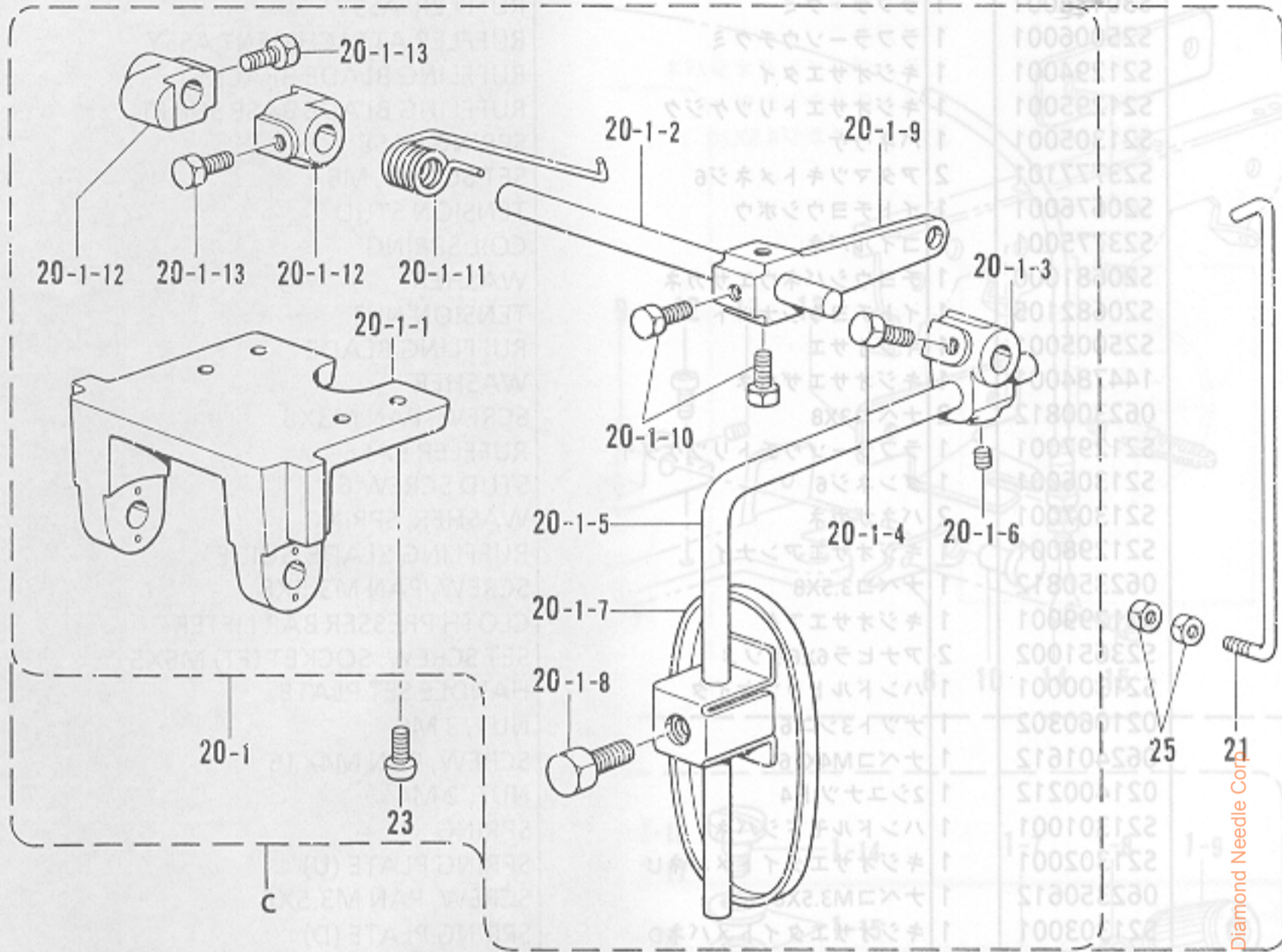

オプションパーツ / OPTION PARTS  
全沈用 / FOR FULL-SUBMERGED

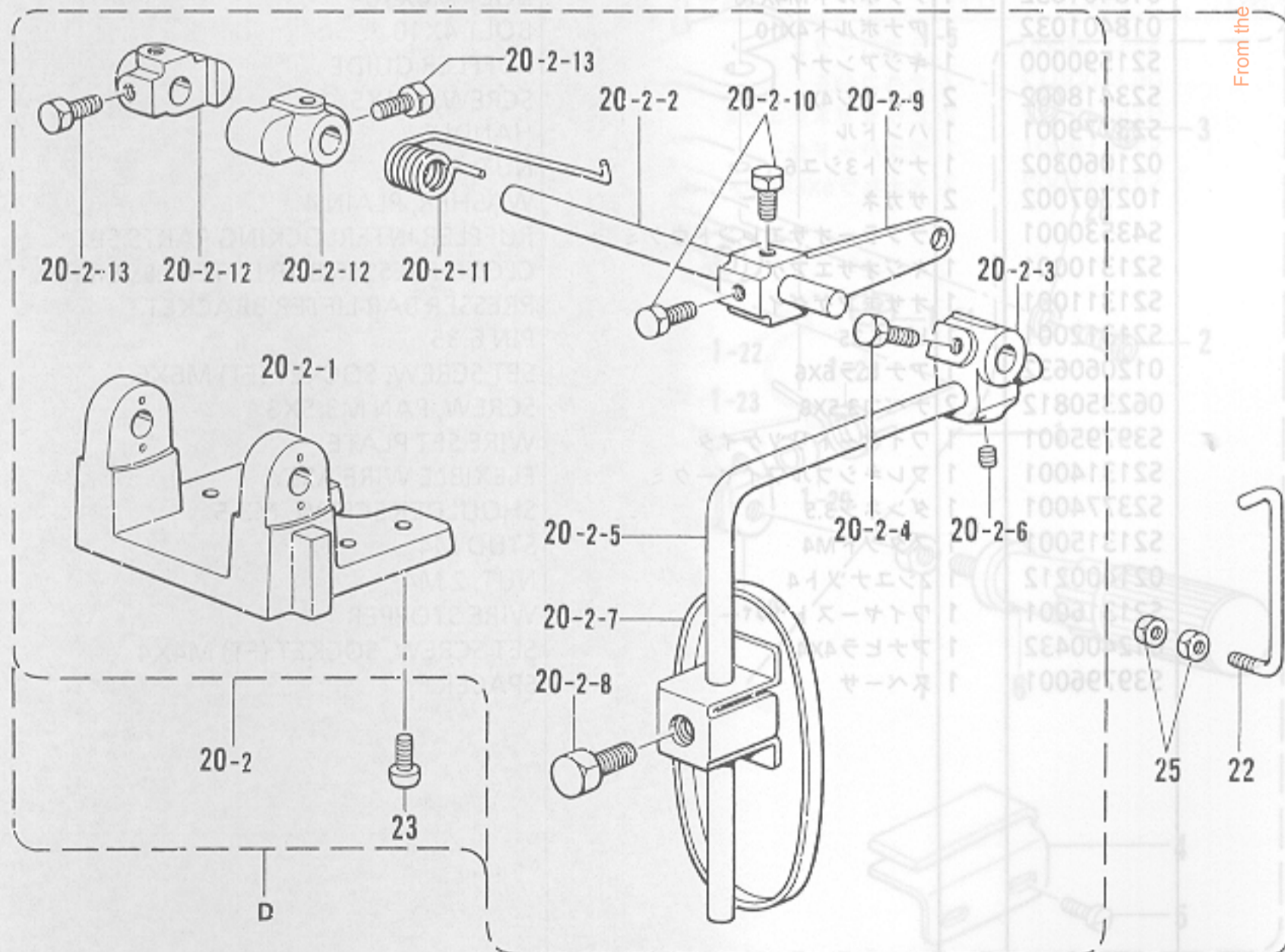

From the library of Diamond Needle Corp.

Q. ラフラー装置 / Ruffling attachment / Kräuselvorrichtung / Accessoire pour fronces  
/ Accesorio de fruncido

REF.NO.	CODE	Q'TY	ヒンメイ	NAME OF PARTS	RM
-1	S23896001	1	<半沈用>	<FOR SEMI-SUBMERGED>	
C	S30135001	1	サドウチヨウセツセット	DIFFERENTIAL FEED ADJUSTER SET	
20-1	S21373001	1	サドウチヨウセツクミ	DIFFERENTIAL FEED ADJUSTER ASSY	
20-1-1	155197101	1	ヒザアテヨコジクウケ	KNEE LIFTER SHAFT BRACKET	
20-1-2	S21375001	1	ヨコジク	KNEE LIFTER SHAFT	
20-1-3	155199101	1	ヒザアテツギテ	KNEE LIFTER BRACKET	
20-1-4	017781012	2	ボルト6.35X10	BOLT, SM6.35X10	
20-1-5	148797001	1	ヒザアゲタテジクS	KNEE LIFTER BAR (S)	
20-1-6	014780622	1	アナトメネジ6.35クボミ	SET SCREW, SOCKET (CP) SM6.35	
20-1-7	148798009	1	ヒザアテL	KNEE LIFTER PLATE (L)	
20-1-8	100463001	1	カクボルト7.94	BOLT, SM7.94	
20-1-9	S21376001	1	ヒザアテレバー	KNEE LIFTER LEVER	
20-1-10	017781012	2	ボルト6.35X10	BOLT, SM6.35X10	
20-1-11	S21377001	1	ヒザアテレバーバネ	SPRING	
20-1-12	S21378001	2	ヨコジクトメグ	COLLAR	
20-1-13	017781012	4	ボルト6.35X10	BOLT, SM6.35X10	
21	S21379001	1	ヒザアテリンク	CONNECTING BAR	
23	062401012	4	ナベコM4X10	SCREW, PAN M4X10	
25	021400202	2	2シユナツト4	NUT, 2 M4	
D	S30135002	1	<全沈用>	<FOR FULL-SUBMERGED>	
20-2	S21380001	1	サドウチヨウセツソウチクミ	DIFFERENTIAL FEED ADJUSTER ASSY	
20-2-1	155197101	1	ヒザアテヨコジクウケ	KNEE LIFTER SHAFT BRACKET	
20-2-2	S21375001	1	ヨコジク	KNEE LIFTER SHAFT	
20-2-3	155199101	1	ヒザアテツギテ	KNEE LIFTER BRACKET	
20-2-4	017781012	2	ボルト6.35X10	BOLT, SM6.35X10	
20-2-5	148797001	1	ヒザアゲタテジクS	KNEE LIFTER BAR (S)	
20-2-6	014780622	1	アナトメネジ6.35クボミ	SET SCREW, SOCKET (CP) SM6.35	
20-2-7	148798009	1	ヒザアテL	KNEE LIFTER PLATE (L)	
20-2-8	100463001	1	カクボルト7.94	BOLT, SM7.94	
20-2-9	S21376001	1	ヒザアテレバー	KNEE LIFTER LEVER	
20-2-10	017781012	2	ボルト6.35X10	BOLT, SM6.35X10	
20-2-11	S21377001	1	ヒザアテレバーバネ	SPRING	
20-2-12	S21378001	2	ヨコジクトメグ	COLLAR	
20-2-13	017781012	4	ボルト6.35X10	BOLT, SM6.35X10	
22	S21381001	1	ヒザアテリンク	CONNECTING BAR	
23	062401012	4	ナベコM4X10	SCREW, PAN M4X10	
25	021400202	2	2シユナツト4	NUT, 2 M4	
8	S21324001	2	ヒザアテヨコセツナツト	PRESSER PLATE ADJUST NUT	
9	025040132	1	ヒラサガネシヨウ4	WASHER, PLAIN S 4	
10	060401012	1	バインドM4X10	SCREW, BIND M4X10	
11	S21325001	1	スタツトM4	STUD M4	
12	021400212	1	2シユナツト4	NUT, 2 M4	
13	S21316001	1	ワイヤーストッパ	WIRE STOPPER	
14	012400032	1	アナトメネジ	SET SCREW, SOCKET (FT) M4X4	
15	S21324001	1	ヒザアテヨコセツナツト	WIRE ASSY	
16	S2377001	1	アナトメネジ	SHOULDER SCREW, M3.5	
17	039797001	1	イトユルメドダイ	TENSION RELEASE BASE	
18	S39798001	1	イトユルメイタ	TENSION RELEASE PLATE	
19	S39799001	1	イト	COLLAR	
20	025040232	1	ヒラサガネシヨウ4	WASHER, PLAIN M 4	
21	062401212	1	ナベコM4X12	SCREW, PAN M4X12	
22	S21325001	1	スタツトM4	THREAD RETAINER	
23	062300512	2	ナベコM3X5	SCREW, PAN M3X5	
24	S39800001	1	イトユルメドダイ	SPRING	
25	S39796001	1	スペーサ	SPACER	

From the library of: Diamond Needle Corp



オプション部品 / OPTION PARTS

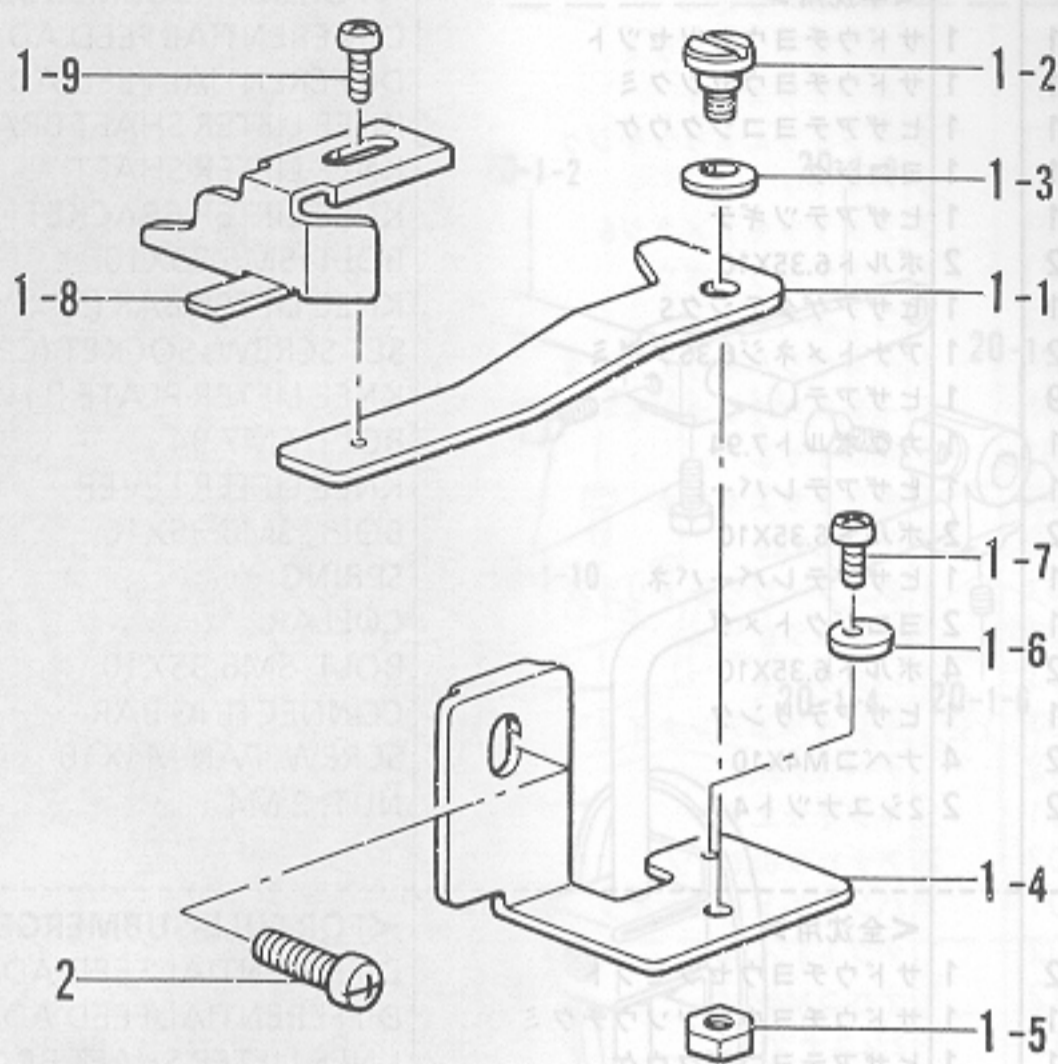

185-N21-236

S. バックタック関係 / Back-tacking / Rückwärtsheftvorrichtung / Point d'arrêt  
 / Pespunte de revés

49

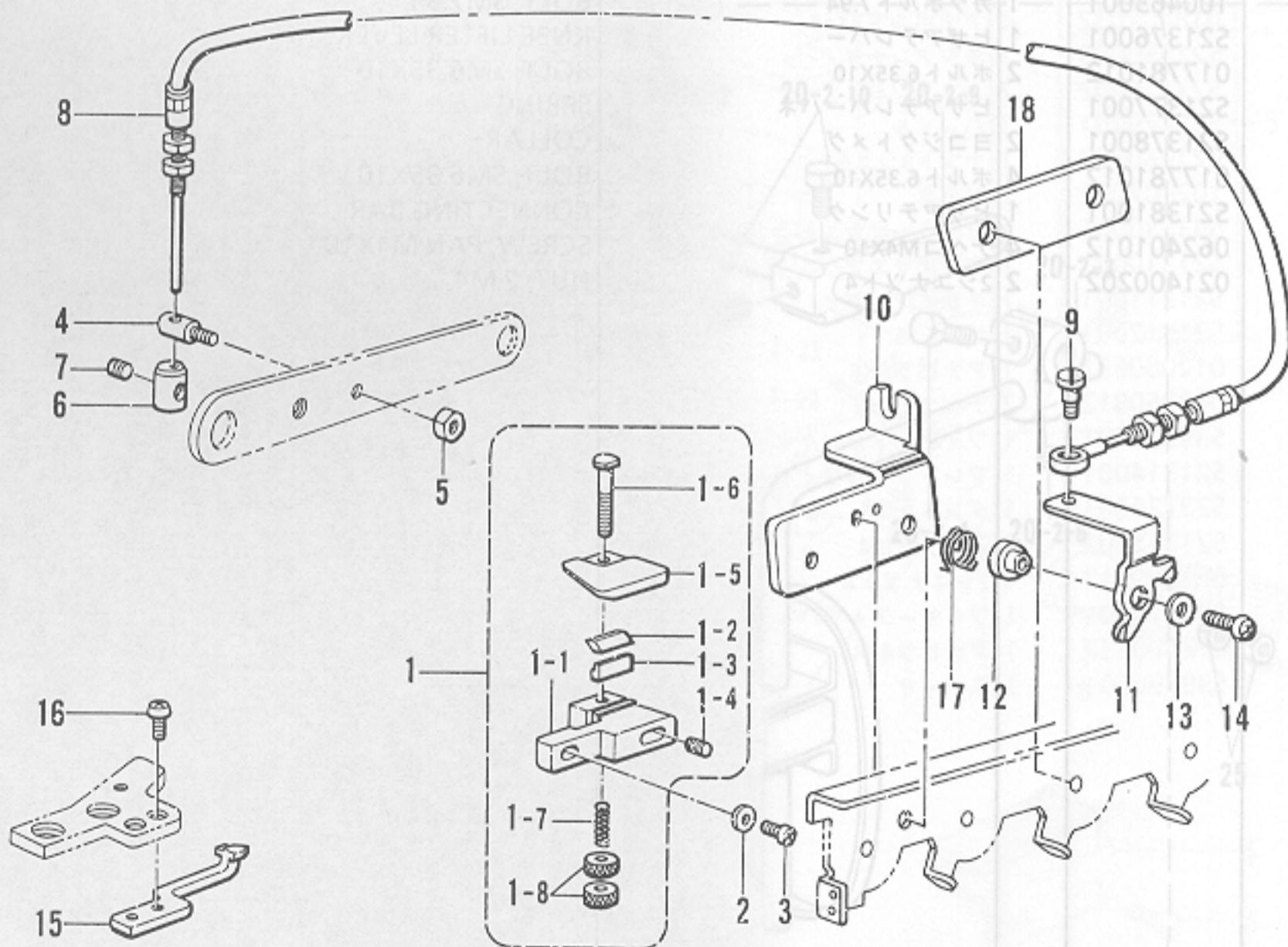

185-N21-237

From the library of: Diamond Needle Corp

R. 縁カガリ定規関係 / Serging attachment / Überwendlichvorrichtung  
 / Accessoire pour couture sur tissus serges / Dispositivo de dobladillo para puntada invisible

REF.NO.	CODE	Q'TY	ヒンメイ	NAME OF PARTS	RM
1	S21336001	1	フチカガリジヨウギクミ	EDGE GUIDE ASSY	
1-1	S23896001	1	ジヨウギトリツケイタ	EDGE GUIDE SET PLATE	
1-2	S23773001	1	ダンネジ4	SHOULDER SCREW, M4	
1-3	146598001	1	バネザガネ	WASHER, SPRING	
1-4	S23897001	1	ジヨウギトリツケイタササエ	EDGE GUIDE SUPPORT	
1-5	021400212	1	2シユナツト4	NUT, 2 M4	
1-6	S21341001	1	ストツパー	STOPPER	
1-7	062300512	1	ナベコ3X5	SCREW, PAN M3X5	
1-8	146762001	1	フチカガリジヨウギ	EDGE GUIDE	
1-9	062350612	1	ナベコM3.5X6	SCREW, PAN M3.5X6	
2	062401012	1	ナベコM4X10	SCREW, PAN M4X10	
19	145277205	1	オイルタンク	OIL TANK	
24	142262001	1	チェーン	CHAIN, F ASSY	
25	122991001	1	フックヒンボリフクロ	ACCESSORY BAG	
27	S20718000	1	トウブウケ	HEAD PLATE	
29	S35997001	4	カクネボルト8X85	BOLT, M8X85	
31	213650001	4	ワ2.3X8.5X385	WASHER, 2.3X8.5X385	
32	028080242	4	バネザガネ2-8	WASHER, SPRING 2-8	
33	021080106	4	ナツト1MB	NUT, 1 MB	
40	S20769000	1	ジヨーゴ	FUNNEL	
41	142225002	1	トウブカバー	HEAD COVER	
48-1	147919001	1	ボウシンゴム	RUBBER CUSHION	
48-2	147919002	1	ボウシンゴム	RUBBER CUSHION	
56	148797009	1	ダスターシユート	DUSTER CHUTE ASSY	
57	021411304	3	マルモク	WOOD SCREW, ROUND M4.1X12	
58	S23353001	1	ダスターシユートササエ	DUSTER SHOOT SUPPORT	
59	062400612	2	ナベコM4X6	SCREW, PAN M4X6	

185N21-236

S. バックタック関係 / Back-tacking / Rückwärtsheftvorrichtung / Point d'arrêt  
 / Pespunte de revés

REF.NO.	CODE	Q'TY	ヒンメイ	NAME OF PARTS	RM
1	S21335001	1	カエシヌイオサエクミ	BACK-TACK PRESSER ASSY	
1-1	S21320001	1	カエシヌイドダイ	BACK-TACK BLADE HOLDER	
1-2	S09234001	1	カエシヌイメス	BACK-TACK KNIFE	
1-3	S09235001	1	カエシヌイメスオサエ	BACK-TACK KNIFE PRESSER	
1-4	012400832	2	アナヒラ4X8	SET SCREW, SOCKET (FT) M4X8	
1-5	S21321001	1	カエシヌイオサエイタ	BACK-TACK PRESSER PLATE	
1-6	S21322001	1	オサエイタオシボウ	PRESSER PLATE SHAFT	
1-7	116794001	1	オシバネ	SPRING, COMPRESSION	
1-8	S21324001	2	オサエイタチヨウセツナツト	PRESSER PLATE ADJUST NUT	
2	025040132	1	ヒラザガネシヨウ4	WASHER, PLAIN S 4	
3	060401012	1	バインドM4X10	SCREW, BIND M4X10	
4	S21315001	1	スタツドM4	STUD M4	
5	021400212	1	2シユナツト4	NUT, 2 M4	
6	S21316001	1	ワイヤーストツパー	WIRE STOPPER	
7	012400432	1	アナヒラ4X4	SET SCREW, SOCKET (FT) M4X4	
8	S21314001	1	フレキシブルワイヤークミ	FLEXIBLE WIRE ASSY	
9	S23774001	1	ダンネジ3.5	SHOULDER SCREW, M3.5	
10	S39797001	1	イトユルメドダイ	TENSION RELEASE BASE	
11	S39798001	1	イトユルメイタ	TENSION RELEASE PLATE	
12	S39799001	1	カラー	COLLAR	
13	025040232	1	ヒラザガネチユウ4	WASHER, PLAIN M 4	
14	062401212	1	ナベコ4X12	SCREW, PAN M4X12	
15	S21326001	1	イトサバキ	THREAD RETAINER	
16	062300512	2	ナベコ3X5	SCREW, PAN M3X5	
17	S39800001	1	イトユルメドシバネ	SPRING	
18	S39796001	1	スペーサ	SPACER	

185-N21-237

Z. 付属品関係 / Accessories / Zubehör / Accessoires / Accesorios

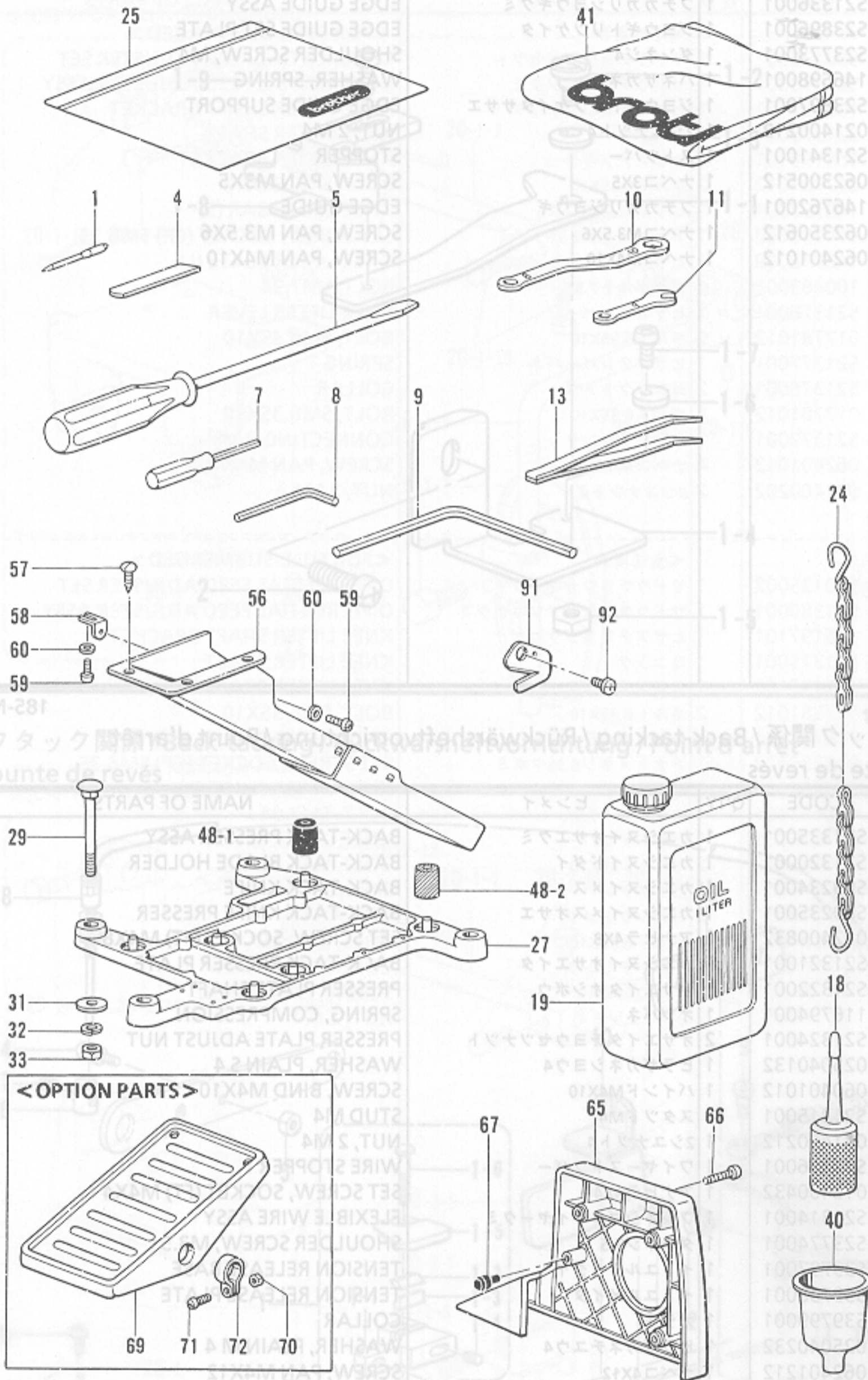

From the library of: Diamond Needle Corp

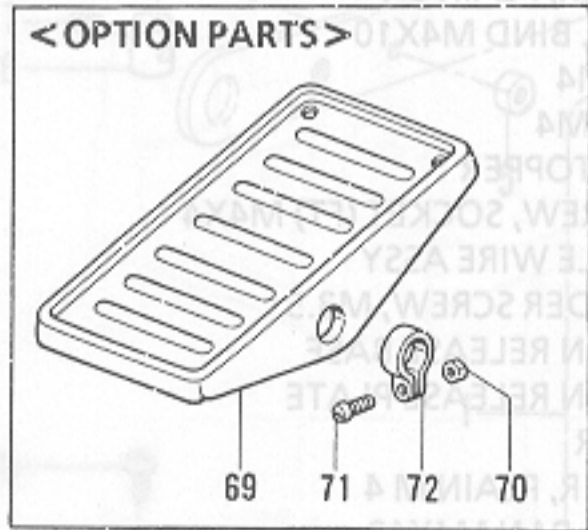

◎ 付属品の明細は変更することがあります。

◎ The details of included accessories are subject to change.

◎ Änderungen in der Aufstellung der Mitgelieferten  
Zubehöre sind vorbehalten.

◎ Les détails des accessoires inclus sont sujets à des changements.

◎ Los detalles de accesorios incluidos pueden variar.

REF.NO.	CODE	Q'TY	ヒンメイ	NAME OF PARTS	RM
1	S29 ※ 109	2	ミシンハリDCX27	NEEDLE DCX27	
4-1	1501 ※ 001	1	シタメス	LOWER KNIFE	
5-2	101572101	1	ネジマワシ5.5X190	SCREW DRIVER, 5.5X190	
7-3	S01943001	1	6カクボウネジマワシ1.6	SCREW DRIVER, 1.6	
8-4	142002001	1	6カクボウスパナ2	HEXAGONAL WRENCH, 2	
9-4-1	149570001	1	6カクボウスパナ5	HEXAGONAL WRENCH, 5	
10-4-2	S23356001	1	メガネレンチ8X10	DOUBLE WRENCH, 8X10	
11-5	S23363001	1	スパナ6	WRENCH, 6	
13-6	117466000	1	ピンセット	PINCETTE	
18-7	S06701000	1	ポリオイラークミ	POLY OILER ASSY	
19-7-1	145277205	1	オイルタンク	OIL TANK	
24-8	142262001	1	クサリフクミ	CHAIN, F ASSY	
25-9	122991001	1	フゾクヒンポリフクロ	ACCESSORY BAG	
27-10	S20718000	1	トウブウケ	HEAD PLATE	
29-10-1	S35997001	4	カクネボルト8X85	BOLT, M8X85	
31-10-2	213650001	4	ワ2.3X8.5X38ST	WASHER, 2.3X8.5X38ST	
32-10-3	028080242	4	バネザガネ2-8	WASHER, SPRING 2-8	
33-11	021080106	4	ナツト1シユ8	NUT, 1 M8	
40-12	S20769000	1	ジョーゴ	FUNNEL	
41-13	144225002	1	トウブカバー	HEAD COVER	
48-1	147919001	1	ボウシンゴム	RUBBER CUSHION	
48-2	147919002	3	ボウシンゴム	RUBBER CUSHION	
56-15-1	183797009	1	ダスターシュートクミ	DUSTER CHUTE ASSY	
57-15-2	031411304	3	マルモクネジ4.1X13	WOOD SCREW, ROUND M4.1X13	
58-15-3	S23353001	1	ダスターシュートササエS	DUSTER SHOOT SUPPORT, S	
59-15-4	062400612	2	ナベコM4X6	SCREW, PAN M4X6	
60-16	025040332	2	ヒラザガネダイ4	WASHER, PLAIN L 4	
65-16-1	S38302020	1	ベルトカバー	BELT COVER	
66-16-2	062061412	3	ナベコ6X14	SCREW, PAN M6X14	
67-16-3	S20412000	1	ゴムセン3.7	RUBBER CAP, 3.7	
69-17	147893009	1	オサエアゲフミイタ	-----	
70-17-1	021400106	2	ナツト1シユ4	-----	
71-17-2	062401406	2	ナベコ4X14	-----	
72-17-3	116016001	2	ベタルトメ	-----	
91	S20118101	1	カラヌイメス	TRIMMING KNIFE	
92	060300512	1	バインドM3X5	SCREW, BIND M3X5	
<b>&lt; OPTION PARTS &gt;</b>					
69	147893009	1	-----	TREADLE PEDAL	
70	021400106	2	-----	NUT, 1 M4	
71	062401406	2	-----	SCREW, PAN M4X14	
72	116016001	2	-----	PEDAL STOPPER	
64-5	017085502	1	ボルトM8X55	BOLT, M8X55	
64-6	025080236	1	ヒラザガネ	WASHER, PLAIN M8	
64-7	028080242	7	バネザガネ2-8	WASHER, SPRING 2-8	
64-8	021080106	1	ナツト1シユ8	NUT, 1 M8	
64-9	213650001	8	ワ2.3X8.5X38ST	WASHER, 2.3X8.5X38ST	
64-10	S20722001	1	ダスターシュートササエL	DUSTER SHOOT SUPPORT, L	
64-11	060400812	2	バインドM4X8	SCREW, BIND M4X8	
64-12	060400812	3	バインドM4X8	SCREW, BIND M4X8	

From the library of: Diamond Needle Corp

付属品の明細は変更することがあります。   
 The details of included accessories are subject to change.   
 付属品の明細は変更することがあります。   
 Los detalles de accesorios incluidos pueden variar.   
 Änderungen in der Aufstellung der Mitgelieferten   
 Zubehörteile sind vorbehalten.

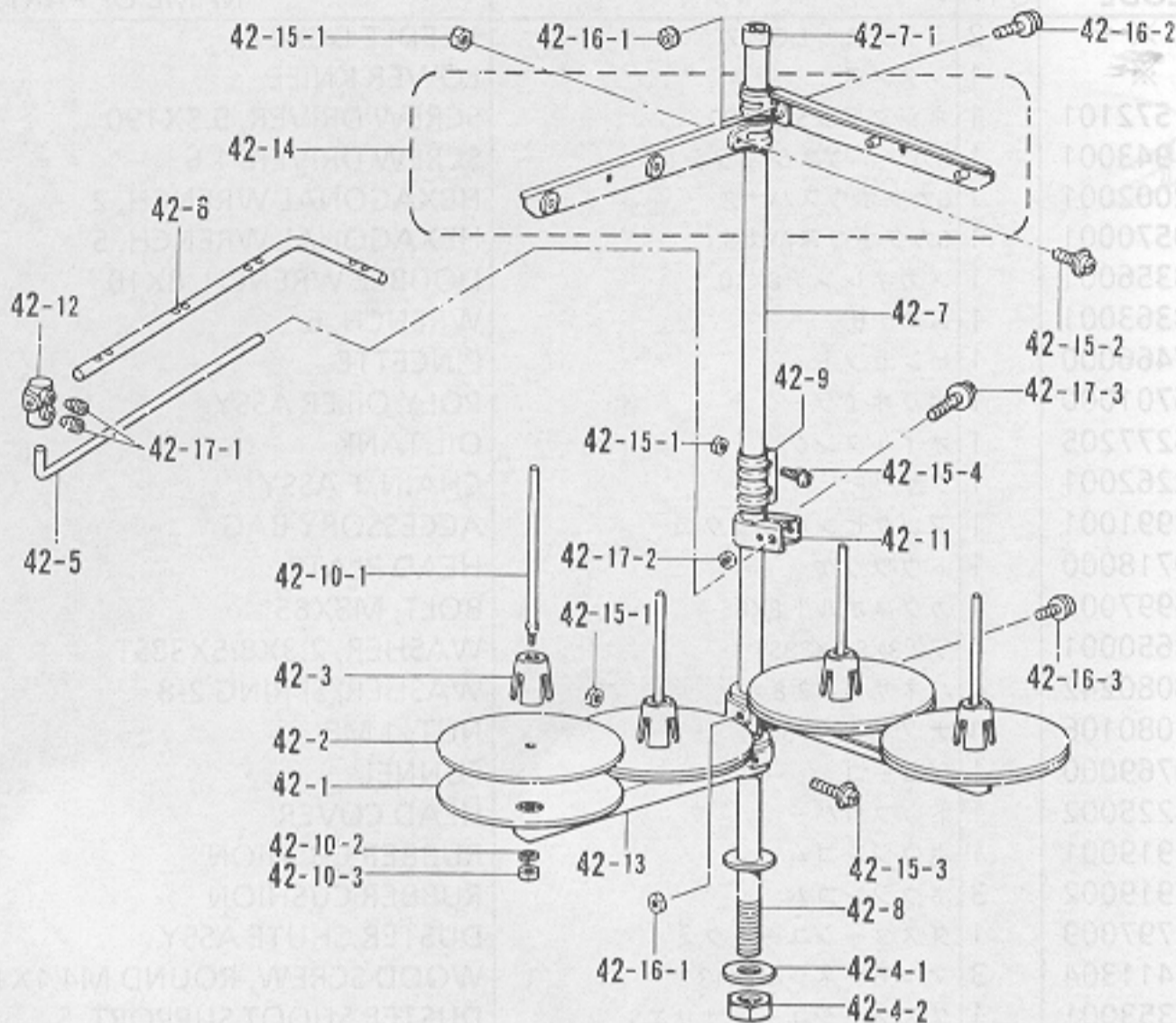

オプションパーツ / OPTION PARTS

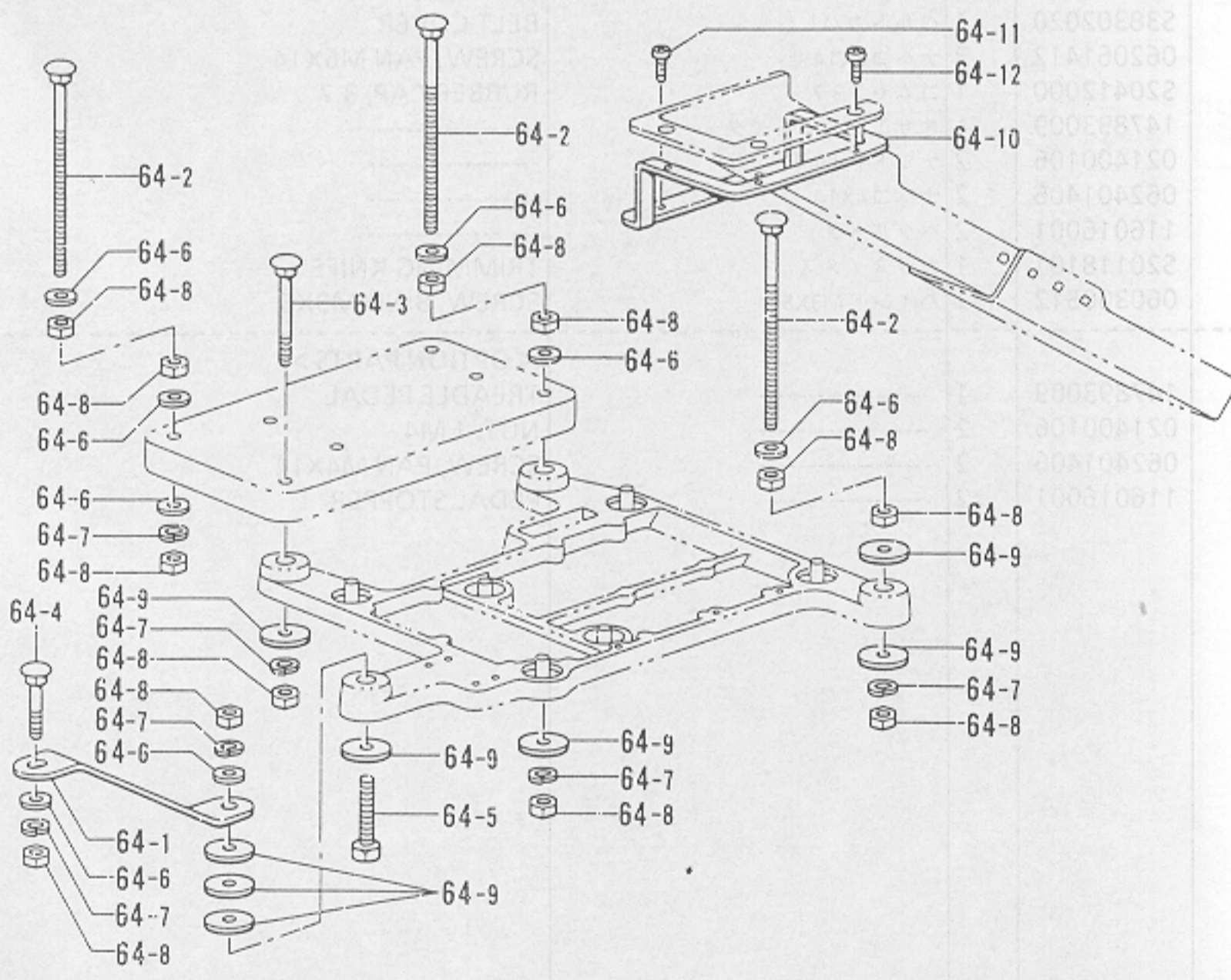

◎ 付属品の明細は変更することがあります。

◎ The details of included accessories are subject to change.

◎ Änderungen in der Aufstellung der Mitgelieferten  
Zubehöre sind vorbehalten.

◎ Les détails des accessoires inclus sont sujets à des changements.

◎ Los detalles des accesorios incluidos pueden variar.









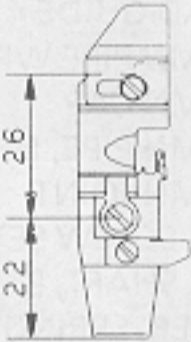
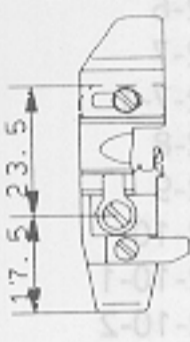

From the library of: Diamond Needle Corp

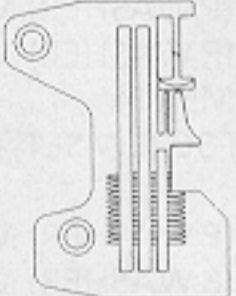
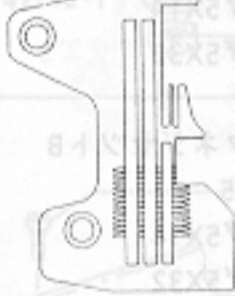
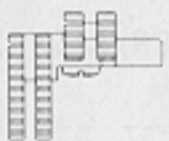
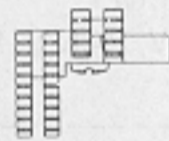
Z. 付属品関係 / Accessories / Zubehör / Accessoires / Accesorios

REF.NO.	CODE	Q'TY	ヒンメイ	NAME OF PARTS	RM
42	S29854109	1	イトタテダイクミ4DTHF	COTTON STAND ASSY, 4DTHF	
42-1	150180001	4	ウケザラ	SPOOL STAND BASE	
42-2	150182000	4	スプールのマット	SPOOL MAT	
42-3	126863001	4	スプールのクッション	SPOOL CUSHION	
42-4	S02775001	1	パイプネジセットA	PIPE SCREW SET, A	
42-4-1	150206002	1	ヒラザガネ16	WASHER, PLAIN 16	
42-4-2	S38648001	1	6カクナツトU5/8	NUT, U5/8-28	
42-5	S04109001	1	イトアンナイササエボウ	THREAD GUIDE SUPPORT BAR	
42-6	142998101	1	イトアンナイ4	THREAD GUIDE 4	
42-7	S40640001	1	コラムパイプキャップツキ	COLUMN PIPE WITH CAP	
42-7-1	150174000	1	コラムキャップ	COLUMN CAP	
42-8	156112003	1	コラムパイプD	COLUMN PIPE, D	
42-9	150173003	1	コラムジョイント	COLUMN JOINT	
42-10	S21798001	4	スプールのネジセット	SPOOL SCREW SET	
42-10-1	150179002	4	スプールのジクB	SPOOL SHAFT, B	
42-10-2	028050246	4	バネザガネ2-5	WASHER, SPRING 2-5	
42-10-3	021500106	4	1シユナツト5	NUT, 1 M5	
42-11	150185009	1	イトアンナイホルダー	THREAD GUIDE HOLDER	
42-12	138843001	1	ササエボウツギテ	JOINT	
42-13	S02778002	2	スプールのホルダー2	SPOOL HOLDER, 2	
42-14	S02786002	2	スレツドハンガークミ2	THREAD HANGER ASSY, 2	
42-15	S40641001	1	スプールのジクネジセットA	SPOOL SCREW SET, A	
42-15-1	021500106	4	1シユナツト5	NUT, 1 M5	
42-15-2	S37038001	1	ナベコヒラザ5X14	SCREW, PAN (P WASHER) M5X14	
42-15-3	S37037001	1	ナベコヒラザ5X32	SCREW, PAN (P WASHER) M5X32	
42-15-4	062501406	2	ナベコ5X14	SCREW, PAN M5X14	
42-16	S40642001	1	スプールのジクネジセットB	SPOOL SHAFT SCREW SET, B	
42-16-1	021500106	2	1シユナツト5	NUT, 1 M5	
42-16-2	S37038001	1	ナベコヒラザ5X14	SCREW, PAN (P WASHER) M5X14	
42-16-3	S37037001	1	ナベコヒラザ5X32	SCREW, PAN (P WASHER) M5X32	
42-17	S40643001	1	ホルダーツギテネジセット	HOLDER JOINT SCREW SET	
42-17-1	014060632	2	アナトメ6X6クボミ	SET SCREW, SOCKET (CP) M6X6	
42-17-2	021500106	1	1シユナツト5	NUT, 1 M5	
42-17-3	S37037001	1	ナベコヒラザ5X32	SCREW, PAN (P WASHER) M5X32	
<オプションパーツ>				<OPTION PARTS>	
64	183798001	1	フルサブマージセット	FULL SUBMERGED SET	
64-1	S20721001	1	トウブウケササエ	HEAD PLATE SUPPORT	
64-2	153318201	4	カクネマルアタマボルト	BOLT	
64-3	S35997001	1	カクネボルト8X85	BOLT, M8X85	
64-4	S36007001	1	カクネボルト8X55	BOLT, M8X55	
64-5	017085502	1	ボルトM8X55	BOLT, M8X55	
64-6	025080236	11	ヒラザガネチユウ8	WASHER, PLAIN M 8	
64-7	028080242	7	バネザガネ2-8	WASHER, SPRING 2-8	
64-8	021080106	15	ナツト1シユ8	NUT, 1 M8	
64-9	213650001	8	ワ2.3X8.5X38ST	WASHER, 2.3X8.5X38ST	
64-10	S20722001	1	ダスターシュートササエL	DUSTER SHOOT SUPPORT, L	
64-11	060400812	2	バインドM4X8	SCREW, BIND M4X8	
64-12	060400812	3	バインドM4X8	SCREW, BIND M4X8	



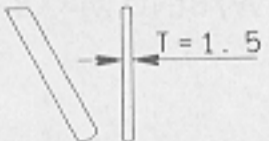







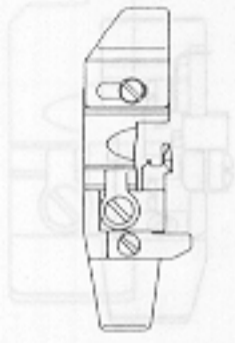
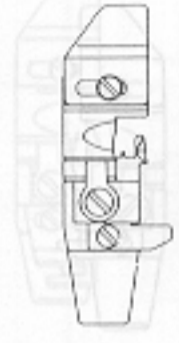

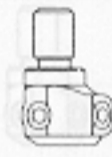
From the library of: Diamond Needle Corp

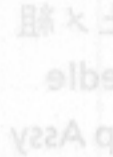
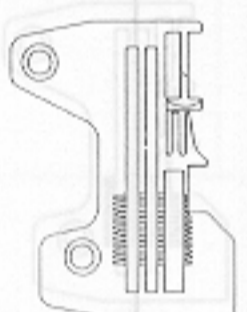
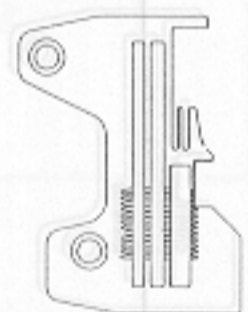
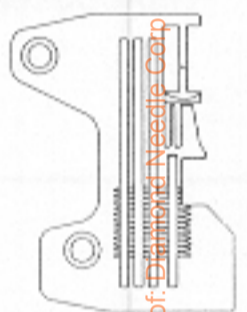
Ga1. ゲージ部品一覧表 / Gauge parts List / Lehrenliste / Liste des Pièces de cartent  
 / Lista d'ePiezas de calibradores

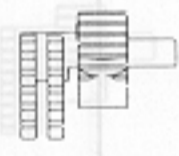
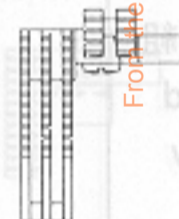
用途 Application	一般地縫用 Thin Medium 1本外し Mock-Safety		一般地縫用 Thin Medium		小回り用 For Small Type 1本外し Mock-Safety	
	サブクラス Sub-Class	22-4, -5 -6, -7	23-5, -6 -7	22-4 (B) -5 (B)	22-6 (B) -7 (B)	22-4 (C), -5(C) -6(C), -7(C)
針幅 (mm) Needle width	2.2		←		←	
1, 針 Needle	151474-011		←		←	
2, 押工組 Presser Foot Assy	S25543-001(4) S19280-001(5) S19282-001(6,7) 		←		S29952-001(4) S29950-001(5) S29951-001(6,7) 	
3, 針止メ組 Needle Clamp Assy	S20398-001 		←		←	
4, 針板 Needle Plate	S25190-001 (4) S19163-001 (6) S19162-001 (5) S25191-001 (7) 		S25527-001 (4) S19170-001 (6) S19169-001 (5) S25193-001 (7) 	←		
5, 主送り歯組 Main Feed Dog Assy	S19217-001 	S19199-001 	S19212-001 	←		
6, 差動送り歯 Differential Feed Dog	S19240-001 	S19236-001 	S19240-001 	←		
7, メス Knife	上メス / Upper Knife 144074-300 		←		←	
8, 下メス Lower Knife	S20582-001 		←		←	
9,  上ルーパ Over Looper	S20424-001, B	S20436-001, F	S20424-001, B	S20424-001, B S20436-001, F		

From the library of: Diamond Needle Corp

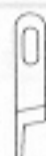
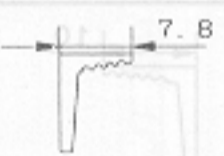

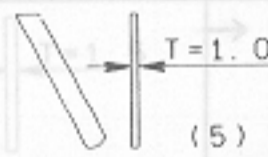
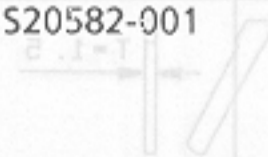
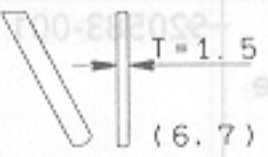



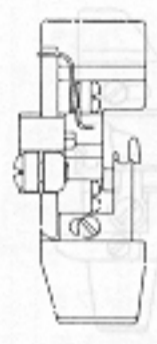
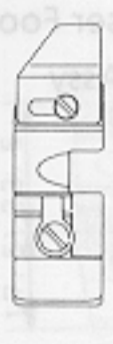

Ga2. ゲージ部品一覧表 / Gauge parts List / Lehrenliste / Liste des Pièces de cartment / Lista d'ePiezas de calibradores

用途 Application	一般地縫用 Thin Medium 1本外し Mock-Safety		バルキーニット用 Bulky Knit 1本外し Mock-Safety		バルキーニット用 Bulky Knit 1本外し Mock-Safety	
	24-5, -6 -7	25-5, -6 -7	27-5, -6 -7	28-5, -6 -7	27-5 (B), -6(B) -7(B)	28-5(B), -6(B) -7(B)
針幅 (mm) Needle width	3		2.2		←	
1, 針 Needle	151474-011		151474-014		←	
2, 押工組 Presser Foot Assy	S19284-001(5) S19285-001(6) S29869-001(7) 		S19287-201(5) S19288-201(6,7) 		S29869-001(7) 	←
3, 針止メ組 Needle Clamp Assy	S20402-001 		S20398-001 		S20402-001 	←
4, 針板 Needle Plate	S19164-001 (5) S19168-001 (7) S19165-001 (6) 		S19166-001 (5) S25192-001 (7) S19167-001 (6) 		S19188-001(6) S25529-001(7) S25528-001(5) 	←
5, 主送り歯組 Main Feed Dog Assy	S19199-001 		S19202-001 		S24680-001 	←
6, 差動送り歯 Differential Feed Dog	S19242-001 		S19237-101 		S30894-101 	←
7, メス Knife	上メス / Upper Knife 144074-300 		角メス / Angle Knife S20897-101 		角メス / Angle Knife S20897-101 	←
8, 下メス Lower Knife	S20899-001 		S20582-001 		S20582-001 	←
9, 上ルーパ Over Looper	(5, 7) S20424-001, B (6) S20432-001, J	(5, 7) S20436-001, F (6) S20434-001, E	S20430-001, D	S20434-001, E	S20430-001, D	S20434-001, E

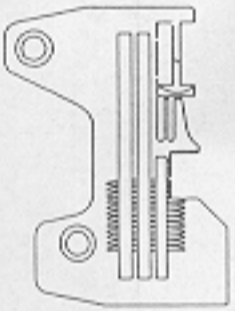
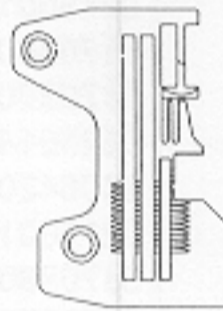
185-N21

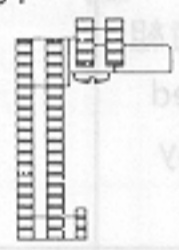

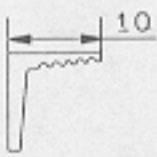

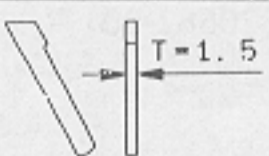
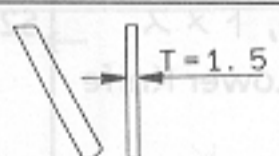



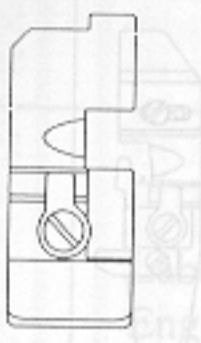
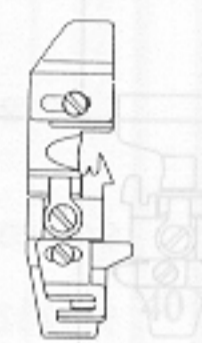
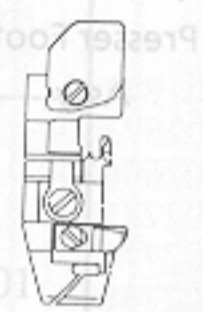

Ga3 . ゲージ部品一覧表 / Gauge parts List / Lehrenliste / Liste des Pièces de cartent  
 / Lista d'ePiezas de calibradores

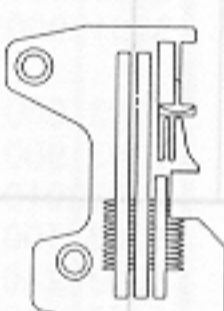
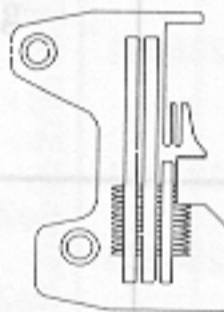
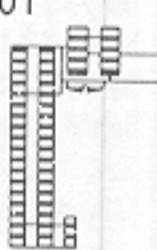
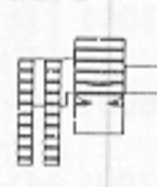
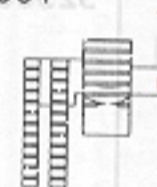
用途 Application	デニム用 Heavy Materials 1本外し Mock-Safety		デニム用 Heavy Materials		ラフラー用 Ruffling 1本外し Mock-Safety	
	31-6, -7	32-6, -7	31-6(B) -7(B)	←	33-5	34-5
針幅 (mm) Needle width	3		←		2.2	
1, 針 Needle	151474-018		←		151474-011	
2, 押工組 Presser Foot Assy	S29871-001(6) S29869-001(7) 	S30898-001 	←		S19291-001 	
3, 針止メ組 Needle Clamp Assy	S20402-001 	←		S20398-001 		
4, 針板 Needle Plate	S24663-001 (6) S24664-001 (7) 	←		S19162-001 		
5, 主送り歯組 Main Feed Dog Assy	S21392-001 	←		S19500-001 		
6, 差動送り歯 Differential Feed Dog	S21395-001 	←		S19243-001 		
7, メス Knife	角メス / Angle Knife S20898-101 	←		上メス / Upper Knife 144074-300 		
8, 下メス Lower Knife	S20583-001 	←		S20582-001 		
9, 上ルーパ Over Looper	S20438-001, G	S20442-001, R	S20438-001, G	←		S20424-001, B S20436-001, F

185-N21

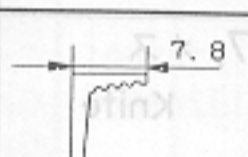
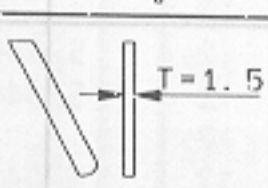
Ga4. ゲージ部品一覧表 / Gauge parts List / Lehrenliste / Liste des Pièces de department / Lista d'ePiezas de calibradores

用途 Application	パイピンググラフラー用 Ruffling W/Piping		テープ用 Taping		バルキーニット(テープ用) Bulky Knit(Taping)	
サブクラス Sub-Class	37-5	38-5	41-5,-6	42-5,-6	45-5,-6 -7	46-5,-6 -7
針幅(mm) Needle width	2.2		←		←	
1, 針 Needle	151474-011		←		151474-014	
2, 押工組 Presser Foot Assy	S25538-001 		S19293-001(5) S25546-001(6) 		S19297-001(5) S19301-001(6,7) 	
3, 針止メ組 Needle Clamp Assy	S20398-001 		← 100-00A05		← 100-88E05	
4, 針板 Needle Plate	S19162-001 		S19169-001(5) S25193-001(7) S19170-001(6) 		← 100-88E05	
5, 主送り歯組 Main Feed Dog Assy	S19500-001 		S19212-001 		S19219-001 	
6, 差動送り歯 Differential Feed Dog	S19243-001 		S19240-001 		S19244-101 	
7, メス Knife	上メス / Upper Knife 144074-300 		← 101-98802		角メス / Angle Knife S20897-101 	
8, 下メス Lower Knife	S20582-001 		← T=1.5		← 100-88205	
9,  上ルーパ Over Looper	S20424-001, B	S20436-001, F	S20424-001, B	S20436-001, F	S20430-001, D	S20434-001, E









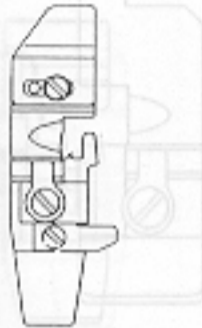

From the library of: Diamond Needle Corp

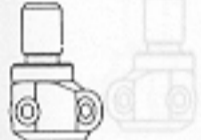
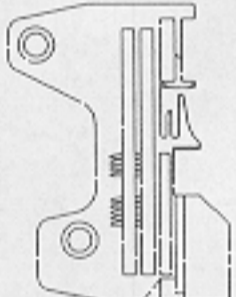
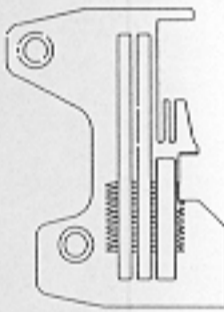
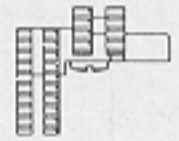
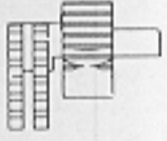
185-N21

185-N21

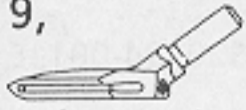

185-N21-052

Ga5 . ゲージ部品一覧表 / Gauge parts List / Lehrenliste / Liste des Pièces de cartment  
 / Lista d'ePiezas de calibradores

用途 Application	バックタック用 Back-Tacking		バルキーニット用 Bulky Knit			
サブクラス Sub-Class	49-5	49-6	57-6	57-7		
針幅 (mm) Needle width	2.2		2.5			
1, 針 Needle	151474-011		151474-014			
2, 押工組 Presser Foot Assy	S19302-001(5,6)		S19303-201(6) S20881-201(7)			
3, 針止メ組 Needle Clamp Assy	S20398-001		S20400-001			
4, 針板 Needle Plate	S19981-001(5) S19982-001(6)		S19173-001(6) S20880-001(7)			
5, 主送り歯組 Main Feed Dog Assy	S25007-001		S19202-001			
6, 差動送り歯 Differential Feed Dog	S25010-001		S19237-101			
7, メス Knife	上メス / Upper Knife 144074-300		角メス / Angle Knife S20897-101			
8, 下メス Lower Knife	S20582-001					
9, 上ルーパ Over Looper	S20424-001, B		S20440-001, K			

From the library of: Diamond Needle Corp

Wa . 警告ラベル / Warning labels / Warnschilder / Etiquettes d'avertissement  
/ Etiquetas de advertencia

	品名 / Name of parts	Size(mm)	Code
	操作注意ラベル・和	40×64	S38350-001
	Label, operation Eng.	40×64	S38349-001
	アースマーク Mark, grounding	φ12	S37060-001

From the library of: Diamond Needle Corp

索引 / INDEX / VERZEICHIS  
/ INDEX / INDICE

CODE	REF.NO.	Page
S00075000	A - 66	4
S01295001	D - 50-1-5	12
	D - 50-3-5	12
	D - 50-4-5	12
	D - 50-5-5	12
	D - 50-15-5	16
	D - 50-19-5	18
	D - 50-21-5	18
	D - 50-25-2	18
S01943001	Z - 7	44
S02573000	E - 38	20
S02606000	A - 3	2
S02775001	Z - 42-4	46
S02778002	Z - 42-13	46
S02786002	Z - 42-14	46
S04109001	Z - 42-5	46
S06701000	Z - 18	44
S06704001	L - 1-4	34
S09234001	S - 1-2	42
S09235001	S - 1-3	42
S19162001	Ga1-4	47
	Ga3-4	49
	Ga4-4	50
S19163001	Ga1-4	47
S19164001	Ga2-4	48
S19165001	Ga2-4	48
S19166001	Ga2-4	48
S19167001	Ga2-4	48
S19168001	Ga2-4	48
S19169001	Ga1-4	47
	Ga4-4	50
S19170001	Ga1-4	47
	Ga4-4	50
S19173001	Ga5-4	51
S19188001	Ga2-4	48
S19199001	Ga1-5	47
	Ga2-5	48
S19202001	Ga2-5	48
	Ga5-5	51
S19212001	Ga1-5	47
	Ga4-5	50
S19217001	Ga1-5	47
S19219001	Ga4-5	50
S19236001	Ga1-6	47
S19237101	Ga2-6	48
	Ga5-6	51
S19240001	Ga1-6	47
	Ga4-6	50
S19242001	Ga2-6	48
S19243001	Ga3-6	49
	Ga4-6	50
S19244101	Ga4-6	50
S19258001	D - 50-1-4	12
	D - 50-3-4	12
	D - 50-4-4	12
	D - 50-5-4	12
	D - 50-15-4	16
	D - 50-21-4	18
S19259001	D - 50-1-6	12
	D - 50-2-6	12
	D - 50-3-6	12
	D - 50-4-6	12
	D - 50-5-6	12

CODE	REF.NO.	Page
S19259001	D - 50-6-6	12
	D - 50-7-6	14
	D - 50-9-3	14
	D - 50-10-6	14
	D - 50-13-6	16
	D - 50-15-6	16
	D - 50-17-6	16
	D - 50-19-6	18
	D - 50-21-6	18
S19279001	D - 50-11-4	14
	D - 50-12-4	14
	D - 50-18-4	16
S19280001	D - 50-1	12
	Ga1-2	47
S19282001	D - 50-3	12
	Ga1-2	47
S19283001	D - 50-3-1	12
	D - 50-7-1	14
	D - 50-12-1	14
	D - 50-21-1	18
S19284001	D - 50-4	12
	Ga2-2	48
S19285001	D - 50-5	12
	Ga2-2	48
S19286001	D - 50-2-1	12
	D - 50-5-1	12
	D - 50-19-1	18
S19287201	D - 50-6	12
	Ga2-2	48
S19288201	D - 50-7	14
	Ga2-2	48
S19291001	D - 50-9	14
	Ga3-2	49
S19293001	D - 50-10	14
	Ga4-2	50
S19296001	D - 50-10-4	14
	D - 50-17-4	16
S19297001	D - 50-11	14
	Ga4-2	50
S19299001	D - 50-11-7	14
	D - 50-12-7	14
S19300001	D - 50-11-5	14
	D - 50-12-5	14
S19301001	D - 50-12	14
	Ga4-2	50
S19302001	D - 50-18	16
	Ga5-2	51
S19303201	D - 50-2	12
	Ga5-2	51
S19311101	D - 50-25-5	18
S19496001	D - 50-1-2	12
	D - 50-2-2	12
	D - 50-3-2	12
	D - 50-4-2	12
	D - 50-5-2	12
	D - 50-6-2	12
	D - 50-7-2	14
	D - 50-9-1	14
	D - 50-10-2	14
	D - 50-11-2	14
	D - 50-12-2	14
	D - 50-13-2	16
	D - 50-14-1	16

CODE	REF.NO.	Page
S19496001	D - 50-15-2	16
	D - 50-17-2	16
	D - 50-18-2	16
	D - 50-19-2	18
	D - 50-21-2	18
S19500001	Ga3-5	49
	Ga4-5	50
S19974001	D - 50-10-1	14
S19975001	D - 50-13-1	16
	D - 50-19-1	18
S19976001	D - 50-1-1	12
	D - 50-4-1	12
	D - 50-6-1	12
	D - 50-11-1	14
	D - 50-21-1	18
S19977001	D - 50-18-1	16
S19981001	Ga5-4	51
S19982001	Ga5-4	51
S20118101	Z - 91	44
S20130009	M - 1	34
S20131009	M - 1-1	34
S20134001	M - 1-1-1	34
S20135001	M - 1-1-1	34
S20199001	J - 9	30
	J - 14	30
S20310001	A - 13	2
S20319001	A - 27-3	2
S20320101	A - 27-5	2
S20321001	A - 27-6	2
S20322101	L - 1-5	34
S20324101	A - 33	2
S20325001	A - 35	2
S20327101	A - 27-8	2
S20338200	A - 61	2
S20339000	A - 62	2
S20340001	A - 69	4
S20342001	A - 70	4
S20345009	A - 10	2
	A - 75	4
S20346000	A - 80	4
S20353000	B - 21	6
S20355002	G - 9-1-2-2	26
	G - 9-2-2-2	26
S20361001	B - 17	6
S20362101	B - 18	6
S20391001	C - 7-5	8
S20392000	C - 7-6	8
S20398001	Ga1-3	47
	Ga2-3	48
	Ga3-3	49
	Ga4-3	50
	Ga5-3	51
S20400001	Ga5-3	51
S20402001	Ga2-3	48
	Ga3-3	49
S20412000	A - 48	2
	A - 55	2
	Z - 67	44
S20415101	C - 21	8
S20416101	C - 22	8
S20424001	Ga1-9	47
	Ga2-9	48
	Ga3-9	49

From the library of: Diamond Needle Corp

CODE	REF.NO.	Page
S20424001	Ga4-9	50
S20424001	Ga5-9	51
S20430001	Ga2-9	48
	Ga4-9	50
S20432001	Ga2-9	48
S20434001	Ga2-9	48
	Ga4-9	50
S20436001	Ga1-9	47
	Ga2-9	48
	Ga3-9	49
	Ga4-9	50
S20438001	Ga3-9	49
S20440001	Ga5-9	51
S20442001	Ga3-9	49
S20453001	L - - 1-1	34
S20460000	L - - 1-1-1	34
S20476001	D - - 4	10
S20485001	D - - 19	10
S20494001	D - - 40	10
S20495001	D - - 42	10
S20526000	E - - 47	20
S20530001	E - - 30	20
S20543101	E - - 51	20
S20544000	E - - 52	20
S20547001	E - - 55	20
S20548001	E - - 59	22
S20560001	E - - 66	22
S20571101	F - - 2	24
S20574001	F - - 8	24
S20575001	F - - 9-1	24
S20576001	F - - 9-2	24
S20577001	F - - 12	24
S20578101	F - - 13	24
S20579101	F - - 15-2	24
S20582001	Ga1-8	47
	Ga2-8	48
	Ga3-8	49
	Ga4-8	50
	Ga5-8	51
S20583001	Ga3-8	49
S20585001	F - - 27	24
S20598000	G - - 2	26
	H - - 3	28
S20622001	H - - 5	28
S20625001	H - - 11	28
S20627001	H - - 14-1	28
S20655101	J - - 1	30
S20657001	J - - 4-1	30
S20668000	J - - 19	30
S20669000	J - - 23	30
S20671000	J - - 21	30
	J - - 22	30
S20673001	K - - 11	32
S20676001	K - - 9	32
	Q - - 1-5	38
S20677000	K - - 10	32
S20678001	K - - 14	32
S20679001	K - - 15	32
S20681000	K - - 18	32
	Q - - 1-8	38
S20682101	K - - 19-2	32
S20682102	K - - 19-4	32
S20682103	K - - 19-1	32

CODE	REF.NO.	Page
S20682104	K - - 19-3	32
S20682105	Q - - 1-9	38
S20684101	K - - 23	32
S20685001	K - - 25	32
S20686001	K - - 26	32
S20687001	K - - 37	32
S20689001	K - - 48	32
S20690001	K - - 49	32
S20691001	K - - 50	32
S20692001	K - - 51	32
S20718000	Z - - 27	44
S20721001	Z - - 64-1	46
S20722001	Z - - 64-10	46
S20769000	Z - - 40	44
S20878000	A - - 82	4
S20880001	Ga5-4	51
S20881201	D - - 50-13	16
	Ga5-2	51
S20896101	F - - 15-2	24
S20897101	F - - 15-2	24
	Ga2-7	48
	Ga4-7	50
	Ga5-7	51
S20898101	F - - 15-2	24
	Ga3-7	49
S20899001	Ga2-8	48
S21128001	K - - 44	32
S21129001	K - - 40	32
S21130001	K - - 42	32
S21133001	K - - 28	32
S21134001	K - - 29	32
S21135001	K - - 31	32
S21136101	K - - 35	32
S21137001	K - - 33	32
S21294001	Q - - 1-1	38
S21295001	Q - - 1-2	38
S21297001	Q - - 1-13	38
S21298001	Q - - 1-16	38
S21299001	Q - - 1-18	38
S21300001	Q - - 1-20	38
S21301001	Q - - 1-24	38
S21302001	Q - - 1-25	38
S21303001	Q - - 1-27	38
S21304001	Q - - 1-29	38
S21305001	Q - - 1-3	38
S21306001	Q - - 1-14	38
S21307001	Q - - 1-15	38
S21310001	Q - - 8	38
S21311001	Q - - 9	38
S21312001	Q - - 10	38
S21314001	Q - - 14	38
	S - - 8	42
S21315001	Q - - 16	38
	S - - 4	42
S21316001	Q - - 18	38
	S - - 6	42
S21318000	P - - 1	36
S21320001	S - - 1-1	42
S21321001	S - - 1-5	42
S21322001	S - - 1-6	42
S21324001	S - - 1-8	42
S21326001	S - - 15	42
S21335001	S - - 1	42

CODE	REF.NO.	Page
S21336001	R - - 1	42
S21341001	R - - 1-6	42
S21373001	Q - - 20-1	40
S21375001	Q - - 20-1-2	40
	Q - - 20-2-2	40
S21376001	Q - - 20-1-9	40
	Q - - 20-2-9	40
S21377001	Q - - 20-1-11	40
	Q - - 20-2-11	40
S21378001	Q - - 20-1-12	40
	Q - - 20-2-12	40
S21379001	Q - - 21	40
S21380001	Q - - 20-2	40
S21381001	Q - - 22	40
S21392001	Ga3-5	49
S21395001	Ga3-6	49
S21590000	Q - - 4	38
S21798001	Z - - 42-10	46
S23337009	A - - 7	2
	A - - 77	4
S23342001	C - - 7-1	8
	C - - 35-2	8
	C - - 36-2	8
	F - - 30-3	24
	G - - 9-1-1	26
	G - - 9-2-1	26
S23350001	A - - 63	4
S23351001	A - - 65	4
S23353001	Z - - 58	44
S23356001	Z - - 10	44
S23357001	A - - 79	4
S23360001	E - - 37	20
	E - - 42	20
S23363001	Z - - 11	44
S23364000	D - - 44	10
S23418002	A - - 30	2
	K - - 27	32
	L - - 1-2	34
	Q - - 5	38
S23452002	K - - 22	32
S23614101	H - - 12	28
S23616101	A - - 25	2
S23621101	E - - 70	22
	E - - 76	22
	E - - 78	22
	F - - 16-1	24
S23626001	H - - 6	28
S23628001	E - - 69	22
S23651002	P - - 5	36
	Q - - 1-19	38
S23773001	R - - 1-2	42
S23774001	Q - - 15	38
	S - - 9	42
S23775001	Q - - 1-7	38
S23777101	Q - - 1-4	38
S23779001	Q - - 6	38
S23896001	R - - 1-1	42
S23897001	R - - 1-4	42
S24663001	Ga3-4	49
S24664001	Ga3-4	49
S24680001	Ga2-5	48
S25005001	Q - - 1-10	38
S25006001	Q - - 1	38

From the library of: Diamond Needle Corp

CODE	REF.NO.	Page
S25007001	Ga5-5	51
S25010001	Ga5-6	51
S25019001	P-4	36
S25190001	Ga1-4	47
S25191001	Ga1-4	47
S25192001	Ga2-4	48
S25193001	Ga1-4	47
	Ga4-4	50
S25527001	Ga1-4	47
S25528001	Ga2-4	48
S25529001	Ga2-4	48
S25538001	D-50-14	16
	Ga4-2	50
S25543001	D-50-15	16
	Ga1-2	47
S25544001	D-50-15-1	16
	D-50-21-1	18
S25546001	D-50-17	16
	Ga4-2	50
S25547001	D-50-17-1	16
S25818001	E-61	22
S27868001	B-16	6
S29700000	G-9-1-3	26
	G-9-2-3	26
S29854109	Z-42	46
S29869001	D-50-19	18
	Ga2-2	48
	Ga3-2	49
S29870001	D-50-19-4	18
S29871001	D-50-19	18
	Ga3-2	49
S29950001	D-50-21	18
	Ga1-2	47
S29951001	D-50-21	18
	Ga1-2	47
S29952001	D-50-21	18
	Ga1-2	47
S30134001	Q-A	38
S30135001	Q-C	40
S30135002	Q-D	40
S30562000	D-28	10
	E-18	20
	G-8	26
S30894101	Ga2-6	48
S30898001	D-50-25	18
	Ga3-2	49
S30900001	D-50-25-1	18
S30902001	D-50-25-3	18
S30904001	D-50-25-4	18
S35997001	Z-29	44
	Z-64-3	46
S36007001	Z-64-4	46
S37037001	Z-42-15-3	46
	Z-42-16-3	46
	Z-42-17-3	46
S37038001	Z-42-15-2	46
	Z-42-16-2	46
S37060001	Wa	52
S37070121	D-34	10
S38301020	A-44	2
S38302020	Z-65	44
S38304001	A-29	2
S38308021	D-5	10

CODE	REF.NO.	Page
S38311100	E-43	20
S38312050	E-24	20
S38313001	G-9-1	26
S38320000	G-9-1-2-1	26
	G-9-2-2-1	26
S38322001	G-9-2	26
S38328051	K-1	32
S38330050	K-46	32
S38349001	Wa	52
S38350001	Wa	52
S38648001	Z-42-4-2	46
S39562001	A-37	2
S39563020	A-24	2
S39564021	A-23	2
S39565001	B-24-2	6
S39566001	C-7	8
S39571021	C-10	8
S39574001	C-8	8
S39575001	D-2	10
S39577000	D-2-1	10
S39578001	E-1	20
S39585001	E-1-3	20
S39586001	E-1-4	20
S39589021	E-8	20
S39593021	E-54	20
S39596021	E-54-1	20
S39597001	J-4	30
S39598000	J-4-4	30
S39599001	J-4-3	30
S39601000	J-4-5	30
S39602000	J-4-7	30
S39603001	J-4-8	30
S39605001	A-2	2
S39606020	A-5	2
S39607001	A-8	2
S39608021	A-11	2
S39610021	A-21	2
S39611001	A-27	2
S39612001	A-27-1	2
S39613001	A-27-2	2
S39623001	A-38	2
S39624021	A-42	2
S39625051	A-49	2
S39626021	A-58	2
S39629021	B-3	6
S39630000	B-10	6
S39631000	B-20	6
S39638011	C-35	8
S39638012	C-35	8
S39641011	C-36	8
S39641012	C-36	8
S39644021	C-2	8
S39645021	C-3	8
S39646021	C-4	8
S39647000	C-5	8
S39648021	C-9	8
S39649021	C-15	8
S39650051	C-17-1	8
S39651051	C-17-2	8
S39652021	C-18-1	8
S39653051	C-23	8
S39658001	D-1	10
S39659021	D-6	10

CODE	REF.NO.	Page
S39660001	D-7	10
S39661001	D-8	10
S39662001	D-9	10
S39663021	D-11	10
S39664001	D-12	10
S39665001	D-15	10
S39666001	D-20	10
S39667021	D-21	10
S39669001	D-23	10
S39670000	D-24	10
S39671021	D-26	10
S39672001	D-29	10
S39673020	E-5	20
S39674001	E-9	20
S39675001	E-10	20
S39676021	E-15	20
S39677021	E-16	20
	F-5	24
	G-4	26
	H-9	28
S39678021	E-17	20
S39679001	E-20	20
S39680001	E-23	20
S39683000	E-26	20
S39684021	E-27	20
S39685001	E-28	20
S39686000	E-44	20
S39687000	E-45	20
S39688001	E-46	20
S39690021	E-36	20
	E-41	20
S39691001	E-39	20
S39692021	E-50	20
S39693001	E-58	22
S39694021	E-64	22
S39695001	E-65	22
S39696011	F-30	24
S39696012	F-30	24
	F-30-2	24
S39704021	F-4	24
S39706001	F-17	24
S39707001	F-19	24
S39708001	F-25	24
S39709021	F-28	24
S39715011	G-19	26
S39715012	G-19	26
S39717021	G-3	26
S39718021	G-5	26
S39720011	H-16	28
S39720012	H-16	28
S39722011	H-17	28
S39722012	H-17	28
S39728021	H-8	28
S39743001	J-3	30
S39744021	J-7	30
	J-12	30
S39745001	J-8	30
S39747001	J-10	30
S39749001	J-13	30
S39751021	J-11	30
S39752021	J-15	30
S39759001	B-1-1	6

From the library of: Diamond Needle Corp

CODE	REF.NO.	Page
S39760001	B - 1-2	6
S39767021	C - 19	8
S39768001	C - 18-2	8
S39769051	E - 40	20
S39770001	D - 17	10
S39771020	A - 14	2
S39773001	E - 35	20
S39775001	B - 24-1	6
S39784001	A - 92	4
S39795001	Q - 13	38
S39796001	Q - 29	38
	S - 18	42
S39797001	S - 10	42
S39798001	S - 11	42
S39799001	S - 12	42
S39800001	S - 17	42
S40640001	Z - 42-7	46
S40641001	Z - 42-15	46
S40642001	Z - 42-16	46
S40643001	Z - 42-17	46
S40866001	H - 14-2	28
S42042021	E - 33	20
S43521000	J - 29-1	30
S43522000	J - 29-2	30
S43523000	J - 29	30
S43524001	L - 1	34
S43530001	Q - 8	38
S43527001	F - 6	24
	G - 6	26
012060632	A - 43	2
	B - 2	6
	B - 25	6
	D - 25	10
	E - 2	20
	E - 6	20
	F - 6-1	24
	G - 6-1	26
	J - 17	30
	Q - 11	38
012400432	A - 27-4	2
	A - 32	2
	D - 30	10
	E - 29	20
	G - 13	26
	J - 4-2	30
	J - 16	30
	Q - 19	38
	S - 7	42
012400832	A - 31	2
	E - 32	20
	S - 1-4	42
012500532	J - 2	30
014060632	Z - 42-17-1	46
014780622	Q - 20-1-6	40
	Q - 20-2-6	40
017060812	H - 7	28
017061612	C - 7-2	8
	C - 35-3-1	8
	C - 36-3-1	8
	F - 30-2-1	24
	G - 9-1-1-2	26
	G - 9-2-1-2	26
017085502	Z - 64-5	46

CODE	REF.NO.	Page
017500812	F - 26	24
017501212	A - 64	4
017781012	Q - 20-1-4	40
	Q - 20-1-10	40
	Q - 20-1-13	40
	Q - 20-2-4	40
	Q - 20-2-10	40
	Q - 20-2-13	40
018061432	E - 53	20
	G - 10	26
	G - 19-2	26
	H - 16-2	28
	H - 17-2	28
	J - 6	30
018061632	D - 22	10
	E - 8-1	20
	E - 34	20
	E - 40-1	20
	E - 60	22
018062532	B - 28	6
	C - 16	8
	D - 13	10
018400832	E - 48	20
018401032	Q - 3	38
018401622	C - 35-1	8
	C - 36-1	8
	F - 30-1-1	24
	G - 19-1-1	26
	H - 16-1-1	28
	H - 17-1-1	28
018401632	Q - 2	38
021060302	Q - 1-21	38
	Q - 7	38
021080106	Z - 33	44
	Z - 64-8	46
021400106	Z - 70	44
	Z - 70	44
021400202	Q - 25	40
	Q - 25	40
021400212	A - 53	2
	D - 18	10
	Q - 1-23	38
	Q - 17	38
	R - 1-5	42
	S - 5	42
021500106	Z - 42-10-3	46
	Z - 42-15-1	46
	Z - 42-16-1	46
	Z - 42-17-2	46
025030132	F - 14	24
025040132	E - 49	20
	F - 11	24
	S - 2	42
025040232	P - 3	36
	S - 13	42
025040332	Z - 60	44
025050132	A - 72	4
025060332	D - 14	10
025080236	Z - 64-6	46
025350332	A - 68	4
	E - 63	22
025710232	E - 12	20
	E - 13	20

CODE	REF.NO.	Page
026260136	D - 50-11-9	14
	D - 50-12-9	14
028050246	Z - 42-10-2	46
028060242	B - 27	6
028080242	Z - 32	44
	Z - 64-7	46
031411304	Z - 57	44
034422006	M - 1-2	34
047301242	E - 1-1-1	20
	E - 1-2-1	20
047301642	D - 2-2	10
047401442	D - 21-1	10
047502242	E - 57	22
047503242	D - 16	10
047602042	A - 54	20
048040342	E - 14	20
048090342	D - 27	10
	E - 19	20
048400242	B - 14	6
060300412	D - 35	10
	K - 30	32
060300512	K - 52	32
	Z - 92	44
060300612	D - 43	10
060350812	A - 67	4
	E - 62	22
060351012	H - 15	28
060400612	A - 12	2
	A - 27-7	2
	A - 27-9	2
	A - 34	2
	A - 36	2
	A - 46	2
	A - 50	2
	A - 59	2
	D - 10	10
	E - 22	20
	K - 24	32
	K - 32	32
	K - 36	32
	K - 41	32
	K - 43	32
	K - 45	32
060400812	A - 15	2
	A - 22	2
	J - 24	30
	Z - 64-11	46
	Z - 64-12	46
060401012	L - 1-3	34
	S - 3	42
060401412	A - 28	2
060630412	D - 50-18-5	16
060630712	E - 75-1	22
061350616	E - 31	20
061400812	A - 26	2
	B - 6	6
	J - 20	30
062060812	F - 18	24
	F - 21	24
062061412	Z - 66	44
062300412	F - 16-2	24
062300512	R - 1-7	42
	S - 16	42



CODE	REF.NO.	Page
062300812	Q - 1-12	38
062350512	Q - 1-28	38
062350612	C - 24	8
	Q - 1-26	38
	R - 1-9	42
062350812	C - 7-4	8
	Q - 1-17	38
	Q - 12	38
062400612	Z - 59	44
062400812	A - 9	2
	B - 5	6
	F - 29	24
	J - 4-6	30
	P - 2	36
062401012	A - 4	2
	B - 22	6
	C - 20	8
	Q - 23	40
	Q - 23	40
	R - 2	42
062401212	A - 52	2
	F - 10-1	24
	J - 4-9	30
	S - 14	42
062401406	Z - 71	44
	Z - 71	44
062401612	A - 81	4
	F - 10-2	24
	Q - 1-22	38
062501406	Z - 42-15-4	46
062630612	D - 50-11-6	14
	D - 50-12-6	14
062670712	D - 41	10
	D - 50-25-6	18
072600000	B - 7	6
076203000	B - 15	6
081005070	E - 11	20
081005670	E - 56	22
081009070	A - 78	4
081010070	E - 25	20
081020070	E - 21	20
081031870	B - 4	6
100032003	A - 40	2
	C - 33	8
100136001	N - 1-4	36
100315002	A - 41	2
100463001	Q - 20-1-8	40
	Q - 20-2-8	40
101118001	N - 2	36
101572101	Z - 5	44
102707002	Q - 28	38
104450101	C - 11	8
105161004	D - 3	10
105288001	D - 50-10-5	14
	D - 50-17-5	16
106640001	D - 50-9-2	14
	D - 50-14-2	16
108494001	N - 1-2	36
108495001	N - 1-3	36
110832009	K - 12	32
116016001	Z - 72	44
	Z - 72	44
116794001	S - 1-7	42

CODE	REF.NO.	Page
117466000	Z - 13	44
118550001	G - 14	26
118735002	C - 7-3	8
	C - 35-3-2	8
	C - 36-3-2	8
	F - 30-2-2	24
	G - 9-1-1-3	26
	G - 9-2-1-3	26
122991001	Z - 25	44
126863001	Z - 42-3	46
138843001	Z - 42-12	46
140325001	A - 74	4
140530002	D - 50-1-7	12
	D - 50-2-7	12
	D - 50-3-7	12
	D - 50-4-7	12
	D - 50-5-7	12
	D - 50-6-7	12
	D - 50-7-7	14
	D - 50-9-4	14
	D - 50-10-7	14
	D - 50-11-8	14
	D - 50-12-8	14
	D - 50-13-7	16
	D - 50-15-7	16
	D - 50-17-7	16
	D - 50-19-7	18
	D - 50-21-7	18
141183000	A - 39	2
142002001	Z - 8	44
142262001	Z - 24	44
142998101	Z - 42-6	46
143767002	N - 1	36
143980001	N - 1-1	36
144074300	F - 15-1	24
	Ga1 - 7	47
	Ga2 - 7	48
	Ga3 - 7	49
	Ga4 - 7	50
	Ga5 - 7	51
144103009	K - 13	32
144225002	Z - 41	44
144784001	Q - 1-11	38
145277205	Z - 19	44
146293001	C - 6	8
146427001	C - 12-1	8
	K - 47	32
146592001	K - 21	32
146598001	A - 71	4
	R - 1-3	42
146762001	R - 1-8	42
147893009	Z - 69	44
	Z - 69	44
147919001	Z - 48-1	44
147919002	Z - 48-2	44
147942001	J - 8-1	30
	J - 10-1	30
	J - 13-1	30
148084001	J - 18	30
148782001	H - 13	28
148797001	Q - 20-1-5	40
	Q - 20-2-5	40
148798009	Q - 20-1-7	40

CODE	REF.NO.	Page
148798009	Q - 20-2-7	40
149570001	Z - 9	44
150173003	Z - 42-9	46
150174000	Z - 42-7-1	46
150179002	Z - 42-10-1	46
150180001	Z - 42-1	46
150182000	Z - 42-2	46
150185009	Z - 42-11	46
150206002	Z - 42-4-1	46
150755001	D - 50-1-3	12
	D - 50-2-3	12
	D - 50-3-3	12
	D - 50-4-3	12
	D - 50-5-3	12
	D - 50-6-3	12
	D - 50-7-3	14
	D - 50-10-3	14
	D - 50-11-3	14
	D - 50-12-3	14
	D - 50-13-3	16
	D - 50-15-3	16
	D - 50-17-3	16
	D - 50-18-3	16
	D - 50-19-3	18
	D - 50-21-3	18
151474011	Ga1 - 1	47
	Ga2 - 1	48
	Ga3 - 1	49
	Ga4 - 1	50
	Ga5 - 1	51
151474014	Ga2 - 1	48
	Ga4 - 1	50
	Ga5 - 1	51
151474018	Ga3 - 1	49
153318201	Z - 64-2	46
154841009	A - 76	4
155162001	C - 7-7	8
	G - 9-1-1-4	26
	G - 9-2-1-4	26
155197101	Q - 20-1-1	40
	Q - 20-2-1	40
155199101	Q - 20-1-3	40
	Q - 20-2-3	40
155247000	F - 3	24
	G - 11	26
	H - 10	28
156112003	Z - 42-8	46
156482000	A - 51	2
183797009	Z - 56	44
183798001	Z - 64	46
213650001	Z - 31	44
	Z - 64-9	46

From the library of: Diamond Needle